

**MICHIGAN DEFENSE FORCE STANDARD  
OPERATING PROCEDURE 670-1**

**Uniform and Insignia**

**Guide to the Wear  
and Appearance of  
Defense Force  
Uniforms and  
Insignia**

**Joint Force Headquarters – Michigan  
Department of Military and Veterans Affairs  
Lansing, MI  
10 July 2021**

**UNCLASSIFIED**

# ***SUMMARY of CHANGES***

AR 670–1

Guide to the Wear and Appearance of Defense Force Uniforms and Insignia

This major revision, dated 10 July 2021—

- This is a complete rewrite and formatting of the standard operating procedure (SOP) and supersedes MIVDF VDF Regulation 40 dated 01 February 2008.
- This SOP supersedes Appearance and Uniform Wear Policy dated 28 July 2018.
- Adds guidance for uniform wear IAW DA PAM 670–1 dated 26 January 2021.
- Adds guidance for authorization for uniform wear IAW AR 670–1 dated 26 January 2021.

# Defense Force Standard Operating Procedure 670-1

Joint Force Headquarters - Michigan  
Department of Military and Veterans Affairs  
Lansing, MI  
Effective Date: 10 July 2021

## Guide to the Wear and Appearance of Defense Force Uniforms and Insignia

---

By Order of the Adjutant General



Official:  
MICHAEL E. EWING  
LTC, MIVDF  
Commanding

---

**History.** This publication is a rewrite and newly formatted publication and supersedes VDF-40, 01 February 2008 as well as Appearance and Uniform Wear Policy, 28 July 2018.

**Summary.** This SOP prescribes the policies and standards for the wear and appearance of the defense force uniforms and insignias.

**Applicability.** This SOP applies to all components, elements, detachments, units, and personnel of the defense force, unless otherwise noted.

**Proponent and exception authority.** The proponent of this SOP is the defense force commander and the defense force Adjutant.

**Michigan defense force management control process.** This SOP contains internal management control provisions and identifies key internal controls that must be evaluated.

**Supplementations.** Supplementations of this SOP and establishment of command and local policies and forms are prohibited without prior written approval from the defense force Adjutant.

**Suggested Improvements.** Suggested improvements which may be considered for this SOP should be forwarded in writing to the proponent agency of this SOP. Adjutant, Michigan State Defense Force, 3411 North Martin Luther King Junior Boulevard, Lansing, MI 48906.

**Distribution.** This publication is available in electronic mode only and is intended for all components, elements, detachments, units and personnel of the defense force.

## **Contents**

### **Chapter 1**

#### **General Information**

Purpose • 1-1, *page 1*

Wear of the uniform • 1-2, *page 1*

### **Chapter 2**

#### **Appearance and Grooming Policies**

Punitive and nonpunitive provisions • 2-1, *page 2*

Nonpunitive provisions • 2-2, *page 2*

Personal appearance policies • 2-3, *page 2*

Hair and fingernail standards and grooming policies • 2-4, *page 2*

Tattoo, branding, and body mutilation policy • 2-5, *page 8*

Jewelry • 2-6, *page 9*

Wear of defense force uniform at national, regional, and local events • 2-7, *page 10*

Uniform appearance and fit • 2-8, *page 11*

Required or prohibited wearing of the defense force uniform • 2-9, *page 12*

Distinctive uniforms and uniform items • 2-10, *page 13*

Civilian clothing • 2-11, *page 13*

Eyeglasses, sunglasses, and contact lenses • 2-12, *page 13*

Identification tags and security identification badges • 2-13, *page 14*

Personal protective or reflective clothing • 2-14, *page 14*

Organizational protective or reflective clothing • 2-15, *page 14*

Heraldic items • 2-16, *page 14*

Religious jewelry, apparel, or articles • 2-17, *page 15*

Religious accommodations • 2-18, *page 16*

Walking Aids • 2-19, *page 19*

### **Chapter 3**

#### **Defense Force Uniforms**

Uniforms • 3-1, *page 20*

Approved Uniforms • 3-2, *page 20*

### **Chapter 4**

#### **Combat Uniforms**

Authorization for wear • 4-1, *page 20*

Occasions for wear • 4-2, *page 20*

### **Chapter 5**

#### **Combat Uniform Ensemble**

Classification • 5-1, *page 21*

Composition • 5-2, *page 21*

Accessories • 5-3, *page 22*

Materials • 5-4, *page 23*

Insignia and accouterments • 5-5, *page 23*

Badges worn on the combat uniform • 5-6, *page 23*

General guidelines • 5-7, *page 23*

Combat uniform coat • 5-8, *page 24*

Combat uniform trousers • 5-9, *page 25*

Headgear • 5-10, *page 25*

### **Chapter 6**

#### **Maternity Work Uniform**

Classification • 6-1, *page 25*

Composition • 6-2, *page 25*  
Accessories • 6-3, *page 26*  
Materials • 6-4, *page 26*  
Insignia and accouterments • 6-5, *page 26*  
Badges worn on the maternity work uniform • 6-6, *page 26*  
General guidelines • 6-7, *page 26*

## **Chapter 7**

### **Accessories**

Classification • 7-1, *page 28*  
Composition • 7-2, *page 28*  
Accessories • 7-3, *page 28*  
Materials • 7-4, *page 28*  
Insignia and accouterments • 7-5, *page 28*  
General guidelines • 7-6, *page 28*

## **Chapter 8**

### **Garrison Culinary and Maternity Uniform-Female**

Classification • 8-1, *page 29*  
Composition • 8-2, *page 29*  
Accessories • 8-3, *page 30*  
Materials • 8-4, *page 30*  
Insignia and accouterments • 8-5, *page 30*  
General guidelines • 8-6, *page 30*

## **Chapter 9**

### **Wear of the Uniform by Retired and Former Members of the Service**

General guidelines • 9-1, *page 31*  
Defense force Army Green Service Uniform (AGSU) Implementation Strategy • 9-2, *page 36*  
General guidelines (AGSU) • 9-3, *page 36*  
Defense force uniform adaptations • 9-4, *page 37*

## **Chapter 10**

### **Uniform Accessories**

General • 10-1, *page 39*  
Bags, backpacks, handbags, and purses • 10-2, *page 39*  
Belts and buckles • 10-3, *page 39*  
Berets • 10-4, *page 40*  
Boots • 10-5, *page 42*  
Buttons • 10-6, *page 42*  
Chaplain's apparel • 10-7, *page 42*  
Coat, black, all weather (male and female) • 10-8, *page 43*  
Cover, cap, rain • 10-9, *page 44*  
Cufflinks and studs • 10-10, *page 44*  
Fleece cap • 10-11, *page 44*  
Garrison cap, Army green • 10-12, *page 44*  
Gloves • 10-13, *page 45*  
Neck gaiter • 10-14, *page 46*  
Neckties, male • 10-15, *page 46*  
Overshoes, black • 10-16, *page 46*  
Shirts, white • 10-17, *page 46*  
Shoes • 10-18, *page 47*  
Socks • 10-19, *page 48*  
Suspenders • 10-20, *page 48*

Sweaters • 10-21, *page 48*  
Umbrella • 10-22, *page 50*  
Undergarments • 10-23, *page 51*  
Windbreaker, black • 10-24, *page 52*  
Shoulder sleeve insignia-current organization • 10-25, *page 53*  
Shoulder sleeve insignia-former wartime service • 10-26, *page 53*  
Insignia, distinguishing, U.S. Army “MICHIGAN” tape, nametape, and nameplate • 10-27, *page 54*  
Defense Force Physical Fitness Uniform (DPFU) • 10-28, *page 56*  
Unauthorized Uniforms • 10-29, *page 56*

## **Chapter 11**

### **Cold Weather Uniform**

General Guidelines • 11-1, *page 56*

## **Chapter 12**

### **Insignia and Accouterments**

General guidelines • 12-1, *page 57*

Insignia of Branch • 12-2, *page 57*

## **Chapter 13**

### **Accessories**

General Guidelines • 13-1, *page 58*

Identification tags • 13-2, *page 58*

Security identification badges • 13-3, *page 58*

Nameplate • 13-4, *page 58*

## **Chapter 14**

### **Wearing of Decorations, Service Medals, Badges, and Unit Awards**

General Guidelines • 14-1, *page 59*

Authorization • 14-2, *page 59*

Order of precedence by category of medals • 14-3, *page 59*

Order of precedence within categories of medals • 14-4, *page 60*

Manner of wear of full-size decorations and service medals • 14-5, *page 60*

Manner of wear of service ribbons • 14-6, *page 60*

Manner of wear of miniature decorations and service medals • 14-7, *page 60*

Manner of wear of unit award emblems • 14-8, *page 60*

Manner of wear of service ribbons • 14-9, *page 61*

Manner of wear of miniature decorations and service medals • 14-10, *page 61*

Manner of wear of unit award emblems • 14-11, *page 61*

Badges authorized for wear • 14-12, *page 61*

Tabs authorized for wear • 14-13, *page 60*

Manner of wear of marksmanship badges • 14-14, *page 62*

Manner of wear of special skills badges on ACU, ASU and AGSU Uniforms • 14-15, *page 62*

Identification badges-Intent • 14-16, *page 63*

Manner of wear of identification badges • 14-17, *page 63*

Manner of wear of foreign badges • 14-18, *page 64*

Manner and wear of shoulder cords • 14-19, *page 64*

## **Chapter 15**

### **Wear of the Uniform by Retired and Former Service Members**

General guidelines • 15-1, *page 64*

Wear by retired personnel • 15-2, *page 64*

Wear by former members • 15-3, *page 64*

## Chapter 16 Alternate Uniform Ensemble

Classification • 16–1 *page 65*

Composition • 16–2, *page 65*

### Figure List

- Figure 2-1 Female Measurement figure, *page 5-6*
- Figure 2-2 Male Measurement figure, *page 7*
- Figure 2-3 Prohibited male haircuts, *page 7*
- Figure 2-4 Hijab, *page 17*
- Figure 2-5 Beard, *page 18*
- Figure 2-6, Turban, *page 19*
- Figure 5-1, Army combat uniform and improved hot weather combat uniform, *page 21*
- Figure 5-2, Cold weather Coat, *page 22*
- Figure 5-3, State defense force beret flash, *page 27*
- Figure 5-4, Wear of the beret, male and female, *page 27*
- Figure 9-1 Officer Army Service Uniform - Male/Female, *page 31*
- Figure 9-2 NCO (E5 and above) Army Service Uniform, *page 31*
- Figure 9-3 Enlisted (E4 and below) Army Service Uniform, *page 32*
- Figure 9-4 Class B Service Blue Army Uniform - Male Officer, *page 32*
- Figure 9-5 Class B Service Blue Uniform - Female Officer, *page 33*
- Figure 9-6 Class B Army Service Uniform (E5 and above) variations, *page 33*
- Figure 9-7 Class B Blue Enlisted (E5 and below) Army Uniform, *page 34*
- Figure 9-8 Class A AGSU Male/Female NCO (E6 and above), *page 34*
- Figure 9-9 Class B Service Blue Female Officer, *page 35*
- Figure 9-10 Class A Service Blue Female Officer, *page 35*
- Figure 9-11 Class A Blue ASU NCO (E4 and below) variations, *page 35*
- Figure 9-12 Class A Blue ASU NCO (E4 and below) variations, *page 35*
- Figure 9-13 Class B Blue ASU Enlisted (E4 and below), *page 36*
- Figure 9-14 Class A AGSU Male/Female NCO (E6 and above), *page 37*
- Figure 9-15 Defense Force/State of Michigan Buttons, *page 37*
- Figure 9-16 Defense Force Officer Collar Devices, *page 38*
- Figure 9-17 Defense Force Nameplate, *page 38*
- Figure 9-18 Cap Devices, *page 38*
- Figure 9-19 Defense Force DUI, *page 38*
- Figure 10-1 Brass belt buckle, *page 40*
- Figure 10-2 Defense Force Black Beret, *page 41*
- Figure 10-3 Army black all-weather coat with officer insignia, *page 41*
- Figure 10-4 Beret with Flash, *page 41*
- Figure 10-5 Coat, all-weather, *page 43*
- Figure 10-6 Garrison cap, *page 45*
- Figure 10-7 Black unisex cardigan, *page 52*
- Figure 10-8 Black pullover, *page 50*
- Figure 10-9 Windbreakers, *page 52*
- Figure 10-10 Beret with flash, *page 52*
- Figure 10-11 Beret with flash, officer, *page 53*
- Figure 10-12 Wearing shoulder sleeve insignia, current organization, *page 53*
- Figure 10-13 Wear of the Michigan flag embroidered insignia, *page 54*
- Figure 10-14 Wearing nametape and Michigan distinguishing nametape, *page 55*
- Figure 12-1 Branch insignia, enlisted, *page 57*
- Figure 12-2 Brand insignia, officer, *page 57*
- Figure 12-3 Chaplain Candidate, all faiths, *page 58*
- Figure 12-4 Christian Chaplain Branch Insignia, *page 58*
- Figure 12-5 Jewish Chaplain Branch Insignia, *page 58*
- Figure 12-6 Officer Candidate Insignia, *page 58*
- Figure 12-7 Warrant Officer Candidate Insignia, *page 58*
- Figure 16-1 Class D (Alternate) uniform, *page 66*

**Table List**

Table B-1, *page 68*

Table C-1, *page 69*

**Appendices**

A Branch Colors, *page 67*

B Clothing Bag list – Mandatory Possession, *page 68*

C Authorized optional purchase clothing list, *page 68*



## Chapter 1 General Information

### **IMPORTANT**

***In general, the defense force will follow the guidelines in Army Regulation 670-1. This SOP is not intended to duplicate AR 670-1, but to focus on grooming standards and the primary duty uniforms of the defense force. If a subject is not covered here, AR 670-1 will be deemed to apply pursuant to Chief National Guard Bureau Instruction CNGBI 5500.01 effective 15 June 2017. Additional guidance can be found in DA PAM 670-1 dated 25 May 2017.***

#### **1-1. Purpose**

a. This SOP prescribes the uniforms that may be worn, the items which may be worn on the uniforms, the manner in which the uniforms are worn and the occasions when the uniforms will, or will not be worn, for all personnel of the Michigan Defense Force. This SOP also prescribes the authorized material, design, accessories, and the wear of ornamentation, insignia, and other heraldic items.

b. Only uniforms, accessories, and insignia prescribed in this SOP, as approved by HQDF, will be worn by personnel of the defense force. Illustrations in this SOP are furnished for informational purposes only.

c. Except when otherwise directed by a unit or detachment commander from the Medical Section, Judge Advocate General's Section, Chaplain Corps, Provost Marshal, Support Operations Command or the Inspector General's Section, the wear of additional optional uniform items will not be authorized.

#### **1-2. Wear of the uniform**

a. The uniform will be worn by all personnel when on duty and may be worn when traveling to and from duty. Duty is defined as performing assignments or duties while at drill, participating in a TAG function or while under orders.

b. All service uniform combinations are authorized for year-round wear. However, appropriate discretion should be used based on weather conditions and duties. Seasonal wear dates will not be established.

c. The wearing of a combination of civilian and defense force clothing on duty, off duty or on a military installation is prohibited. Wear of defense force clothing with insignia with civilian clothing at any time is also prohibited. Commercial rucksacks, gym bags, laptop cases or similar items may be worn over the shoulders while in uniform, except when riding on a bicycle or motorcycle. Only one bag may be worn at one time unless unusual circumstances require the shouldering of an additional bag.

d. The wear of uniforms is prohibited under the following conditions:

(1) In connection with the furtherance of any political or commercial interest or when engaged in civilian employment or activities, except as authorized by competent authority.

(2) When participating in public speeches, interviews, picket lines, marches, rallies, or public demonstrations, except as authorized by competent authority.

(3) When attending any meeting or event which is a function of, or sponsored by, an extremist organization.

(4) In establishments that primarily sell alcohol. If the establishment sells alcohol and food, service members may not wear uniforms if their activities in the establishment center on drinking alcohol only.

(5) The duty uniform shall not be worn at movie theaters, exotic dance clubs, or during any other recreational or leisure pursuits.

(6) When wearing the uniform would bring discredit to the service member, the defense force, or the State of Michigan.

e. Headgear will be worn with all uniforms except under the following circumstances:

(1) When the wear of uniform headgear compromises safety. For example: the wear of industrial hard hats or a motorcycle helmet with the uniform is acceptable when required for safety.

(2) When riding in/on privately owned or commercial vehicles or public conveyance.

(3) Headgear will not be worn indoors or under cover unless under arms in an official capacity or directed by the commander (e.g., indoor ceremonial activities).

(4) When not worn, headgear will be carried, not attached to the uniform, or hung from the belt.

Exception: The patrol cap may be folded flat and carried in the trouser cargo pocket.

(5) Service members are not required to wear headgear with any dress uniform to an evening (after retreat) social event.

f. The uniform may be worn off duty, meaning without orders, by members in good standing for limited ceremonial occasions, and for travel to and from such occasions. Acceptable occasions are military funerals or memorial activities, military weddings, and award presentations or recognition activities of a military nature. Any off-duty wear of the uniform is subject to all the provisions of this SOP and approval from leadership must be requested.

## **Chapter 2**

### **Appearance and Grooming Policies**

#### **2-1. Punitive and nonpunitive provisions**

All service members should be aware that portions of Defense Force SOP 670-1, chapter two contains policy provisions that are punitive; violations of the specific prohibitions may result in adverse administrative action and/or charges under the provisions of the Michigan Code of Military Justice.

#### **2-2. Nonpunitive provisions**

The DA Pam 670-1 provides procedural guidance with respect to the policy contained in Defense Force SOP 670-1 and AR 670-1. There are no punitive provisions in the DA Pam.

#### **2-3. Personal appearance policies**

a. Service members will present a professional image at all times and will continue to set the example in military presence, both on and off duty. Pride in appearance includes service members' physical fitness and adherence to acceptable weight standards in accordance with AR 600-9 and Defense Force SOP 600-9.

b. A vital ingredient of the defense force's strength and military effectiveness is the pride and self-discipline service members bring to their service through a conservative military image. It is the responsibility of commanders to ensure that military personnel under their command present a neat and service member appearance. Therefore, in the absence of specific procedures or guidelines, commanders must determine a service member's compliance with standards in this SOP.

c. The defense force uniform SOPs for standards of personal appearance and grooming are as specific as is practicable in order to establish the parameters with which service members must comply.

d. Service members may wear religious apparel, articles, or jewelry with the uniform, to include the improved physical fitness uniform, as authorized by paragraph 2-17 of this SOP. Requests for other religious accommodations related to the wear and appearance of the uniform, personal appearance, and personal grooming practices must be submitted in accordance with Defense Force Regulation 600-20. Wear and appearance standards for service members with approved religious accommodations for hijabs, beards, and turbans are provided in paragraph 2-18.

e. Portions of this chapter are punitive. Violation of the specific prohibitions and requirements set forth in this chapter may result in adverse administrative action and/or charges under the provision of the MCMJ.

#### **2-4. Hair and fingernail standards and grooming policies**

*Note.* This paragraph is punitive with regard to service members. Violation by service members may result in adverse administrative action and/or charges under the provisions of the MCMJ.

##### **a. Hair.**

(1) General. The requirement for hair grooming standards is necessary to maintain uniformity within a military population. Many hairstyles are acceptable, as long as they are neat and conservative. It is the responsibility of leaders at all levels to exercise good judgment when enforcing defense force policy. All service members will comply with hair, fingernail, and grooming policies while in any military uniform, or in civilian clothes on duty.

(a) Leaders will judge the appropriateness of a particular hairstyle by the guidance in this chapter and by the ability to wear all types of headgear (such as beret, patrol cap, or service cap/hat) and any protective equipment (such as protective mask or combat helmet) properly. Hairstyles (including bulk and length of hair) that do not allow service members to wear any headgear properly, or that interfere with the proper wear of any protective equipment, are prohibited. Headgear will fit snugly and comfortably, without bulging or distortion from the intended shape of the headgear and without excessive gaps between the headgear and the head. Hairstyles that pose a health or safety hazard are not authorized.

(b) Extreme, eccentric, or faddish haircuts or hairstyles are not authorized. If service members use dyes, tints, or bleaches, they must choose a natural hair color. Colors that detract from a professional military appearance are

prohibited. Therefore, service members must avoid using colors that result in an extreme appearance. Applied hair colors that are prohibited include, but are not limited to, purple, blue, pink, green, orange, bright (fire-engine) red, and fluorescent or neon colors. It is the responsibility of leaders to use good judgment in determining if applied colors are acceptable, based upon the overall effect on a service member's appearance.

(c) Service members who have a texture of hair that does not part naturally may cut a part into the hair or style the hair with one part. The part will be one straight line, not slanted or curved, and will fall in the area where the service member would normally part the hair. Service members will not shape or cut designs into their hair or scalp.

(2) Male haircuts. The hair on top of the head must be neatly groomed. The length and bulk of the hair may not be excessive and must present a neat and conservative appearance. The hair must be tapered in appearance. A tapered appearance is one where the outline of the service member's hair conforms to the shape of the head, curving inward to the natural termination point at the base of the neck. When the hair is combed, it will not fall over the ears or eyebrows, or touch the collar, except for the closely cut hair at the back of the neck. The block-cut fullness in the back is permitted to a moderate degree, as long as the tapered look is maintained. Males are not authorized to wear braids, cornrows, twists, dreadlocks, or locks while in uniform or in civilian clothes on duty. Haircuts with a single, untapered patch of hair on the top of the head (not consistent with natural hair loss) are considered eccentric and are not authorized. Examples include, but are not limited to, when the head is shaved around a strip of hair down the center of the head (mohawk), around a u-shaped hair area (horseshoe), or around a patch of hair on the front top of the head (tear drop). Hair that is completely shaved or trimmed closely to the scalp is authorized. (See figs 2-1 and 2-2.)

(a) Sideburns. Sideburns are hair grown in front of the ear and below the point where the top portion of the ear attaches to the head. Sideburns will not extend below the bottom of the opening of the ear (see line A of Figure 3-1). Sideburns will not be styled to taper, flair, or come to a point. The length of the individual hairs of the sideburn will not exceed 1/8 inch when fully extended.

(b) Facial hair. Males will keep their face clean-shaven when in uniform, or in civilian clothes on duty. Mustaches are permitted. If worn, males will keep mustaches neatly trimmed, tapered, and tidy. Mustaches will not present a chopped off or bushy appearance, and no portion of the mustache will cover the upper lip line, extend sideways beyond a vertical line drawn upward from the corners of the mouth, or extend above a parallel line at the lowest portion of the nose. Handlebar mustaches, goatees, and beards are not authorized. If appropriate medical authority allows beard growth, the maximum length authorized for medical treatment must be specific. For example, "The length of the beard cannot exceed 1/4 inch". Service members will keep the growth trimmed to the level specified by the appropriate medical authority, but are not authorized to shape the hair growth (examples include, but are not limited to, goatees, "Fu Manchu," or handlebar mustaches).

(c) Wigs and hairpieces. Males are prohibited from wearing wigs or hairpieces while in uniform, or in civilian clothes on duty, except to cover natural baldness or physical disfigurement caused by accident or medical procedure. When worn, wigs or hairpieces will conform to the standard haircut criteria, as stated within this SOP.

(3) Female haircuts and hairstyles. The illustrations provided in figure 2-1 are intended only to clarify language regarding authorized hair lengths and bulks. The requirements for hair SOPs are to maintain uniformity within a military population for female service members while in uniform, or in civilian clothes on duty, unless otherwise specified. Female hairstyles may not be eccentric or faddish and will present a conservative, professional appearance. For the purpose of this SOP, female hairstyles are organized into three basic categories: short length, medium length, and long length hair.

(a) Short length. Short hair is defined as hair length that extends no more than one inch from the scalp (excluding bangs). Hair may be no shorter than 1/4 inch from the scalp (unless due to medical condition or injury) but may be evenly tapered to the scalp within two inches of the hairline edges. Bangs, if worn, may not fall below the eyebrows, may not interfere with the wear of all headgear, must lie neatly against the head, and not be visible underneath the front of the headgear. The width of the bangs may extend to the hairline at the temple.

(b) Medium length. Medium hair is defined as hair length that does not extend beyond the lower edge of the collar (in all uniforms) and extends more than 1 inch from the scalp. Medium hair may fall naturally in uniform and is not required to be secured. When worn loose, graduated hairstyles are acceptable, but the length, as measured from the end of the total hair length to the base of the collar, may not exceed one inch difference in length, from the front to the back. Layered hairstyles are also authorized, so long as each hair's length, as measured from the scalp to the hair's end, is generally the same length giving a tapered appearance. No portion of the bulk of the hair, as measured from the scalp, will exceed two inches.

(c) Long length. Long hair is defined as hair length that extends beyond the lower edge of the collar. Long hair will be neatly and inconspicuously fastened or pinned above the lower edge of the collar, except that bangs may be

worn. No portion of the bulk of the hair, as measured from the scalp as styled, will exceed two inches (except a bun, which is worn on the back of the head and may extend a maximum of 3 1/2 inches from the scalp and be no wider than the width of the head).

(d) Additional hairstyle guidelines. Faddish and exaggerated styles, to include shaved portions of the scalp other than the neckline, designs cut in the hair, unsecured ponytails (except during physical training), and unbalanced or lopsided hairstyles are prohibited. Hair will be styled so as not to interfere with the proper wear of all uniform headgear. All headgear will fit snugly and comfortably around the largest part of the head without bulging or distortion from the intended shape of the headgear and without excessive gaps. When headgear is worn, hair should not protrude at distinct angles from under the edges. Hairstyles that do not allow the headgear to be worn in this manner are prohibited. Examples of hairstyles considered to be faddish or exaggerated and thus not authorized for wear while in uniform or in civilian clothes on duty include but are not limited to hair sculpting (eccentric texture or directional flow of any hairstyle to include spiking); buns with loose hair extending at the end; hairstyles with severe angles or designs; and loose unsecured hair (not to include bangs) when medium and long hair are worn up.

(e) Devices. Hair holding devices are authorized only for the purpose of securing the hair. Service members will not place hair holding devices in the hair for decorative purposes. All hair holding devices must be plain and of a color as close to the service member's hair as is possible or clear. Authorized devices include, but are not limited to, small plain scrunchies (elastic hair bands covered with material), barrettes, combs, pins, clips, rubber bands, and hair/head bands. Such devices should conform to the natural shape of the head. Devices that are conspicuous, excessive, or decorative are prohibited. Some examples of prohibited devices include, but are not limited to: large, lacy scrunchies; beads, bows, or claw or alligator clips; clips, pins, or barrettes with butterflies, flowers, sparkles, gems, or scalloped edges; and bows made from hair pieces. Foreign material (e.g. beads and decorative items) will not be used in the hair. Service members may not wear hairnets unless they are required for health or safety reasons, or in the performance of duties (such as those in a dining facility). No other type of hair covering is authorized in lieu of the hairnet. The commander will provide the hairnet at no cost to the service member.

(f) Braids, cornrows, twists, and locks. Medium and long hair may be styled with braids, cornrows, twists, or locks (see glossary for definitions). Each braid, cornrow, twist, or lock will be of uniform dimension, have a diameter no greater than one half inch, and present a neat, professional, and well-groomed appearance. Each must have the same approximate size of spacing between the braids, cornrows, twists, or locks. Each hairstyle may be worn against the scalp or loose (free hanging). When worn loose, such hairstyles must be worn per medium hair length guidelines or secured to the head in the same manner as described for medium or long length hair styles. Ends must be secured inconspicuously. When multiple loose braids, twists or locks are worn, they must encompass the whole head. When braids, cornrows, twists, or locks are not worn loosely and instead worn close to the scalp, they must stop at one consistent location of the head and must follow the natural direction of the hair when worn back, which is either in general straight lines following the shape of the head or flowing with the natural direction of the hair when worn back with one primary part in the hair. Hairstyles may not be styled with designs, sharply curved lines, or zigzag lines. Only one distinctive style (braided, rolled, twisted, or locked) may be worn at one time. Braids, cornrows, twists, or locks that distinctly protrude (up or out) from the head are not authorized. The bulk of the hair may not be such that it impairs the ability to wear the advanced combat helmet (ACH) or other protective equipment or impedes the ability to operate one's assigned weapon, military equipment, or machinery. A fully serviceable ACH including all its component parts must be worn in accordance with its technical manual to ensure a proper fit for safety.

(g) Hair extensions. Hair extensions are authorized. Extensions must have the same general appearance as the individual's natural hair and otherwise conform to this SOP.

(h) Wigs. Wigs, if worn in uniform or in civilian clothes on duty, must look natural and conform to this SOP. Wigs are not authorized to cover up unauthorized hairstyles.

(i) Physical training. Long length hair may be worn in a ponytail during physical training. A single ponytail centered on the back of the head is authorized in physical fitness uniforms only when within the scope of physical training, except when considered a safety hazard. Ponytails are not required to be worn above the collar. When hair securing devices are worn, they will comply with the guidelines set in paragraph 2-2a(3)(e). Hairstyles otherwise authorized in this chapter (such as braids, twists, and locks) may also be worn in a ponytail during physical training.

(j) Physical training in utility uniforms. Ponytails are authorized using guidelines set forth in paragraph 2-2a(3)(j), while conducting physical training in utility uniforms. However, if the helmet is worn during physical training, hair must be secured using guidelines in paragraph 2-2a(3)(a) through (k).

#### b. Cosmetics.

(1) Standards regarding cosmetics are necessary to maintain uniformity and to avoid an extreme or unprofessional appearance. Males are prohibited from wearing cosmetics, except when medically prescribed.

Females are authorized to wear cosmetics with all uniforms, provided they are applied modestly and conservatively, and that they complement both the service member's complexion and the uniform. Leaders at all levels must exercise good judgment when interpreting and enforcing this policy.

(2) Eccentric, exaggerated, or faddish cosmetic styles and colors, to include makeup designed to cover tattoos, are inappropriate with the uniform and are prohibited. Permanent makeup, such as eyebrow or eyeliner, is authorized as long as the makeup conforms to the standards outlined above. Eyelash extensions are not authorized unless medically prescribed.

(3) Females will not wear shades of lipstick that distinctly contrast with the natural color of their lips, that detract from the uniform, or that are faddish, eccentric, or exaggerated.

(4) Females will comply with the cosmetics policy while in any military uniform or while in civilian clothes on duty.

c. **Fingernails.** All personnel will keep fingernails clean and neatly trimmed. Males will keep nails trimmed so as not to extend beyond the fingertip unless medically required and are not authorized to wear nail polish. Females will not exceed a nail length of  $\frac{1}{4}$  inch as measured from the tip of the finger. Females will trim nails shorter if the commander determines that the longer length detracts from a professional appearance, presents a safety concern, or interferes with the performance of duties. Females may only wear clear polish when in uniform or while in civilian clothes on duty. Females may wear clear acrylic nails, provided they have a natural appearance and conform to Army standards.

d. **Hygiene and body grooming.** Service members will maintain good personal hygiene and grooming on a daily basis and wear the uniform so as not to detract from their overall military appearance.

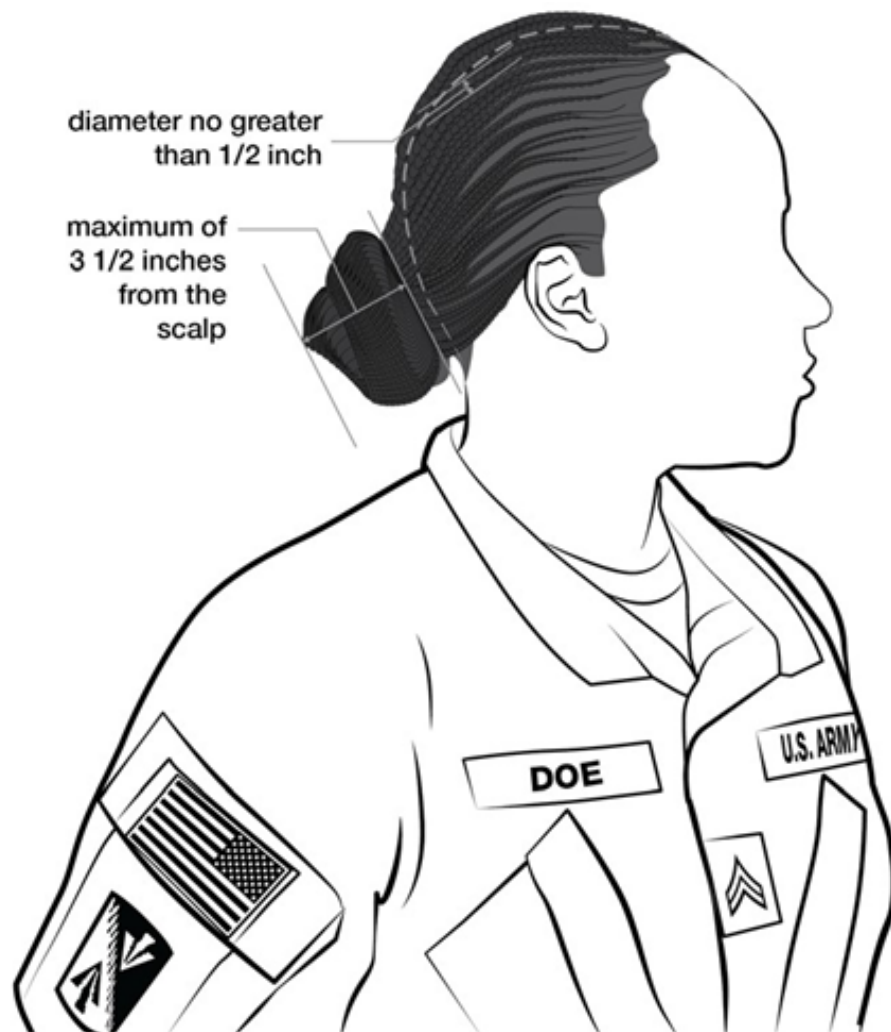

**Hairstyle standards Female**

Figure 2-1. Measurement figure

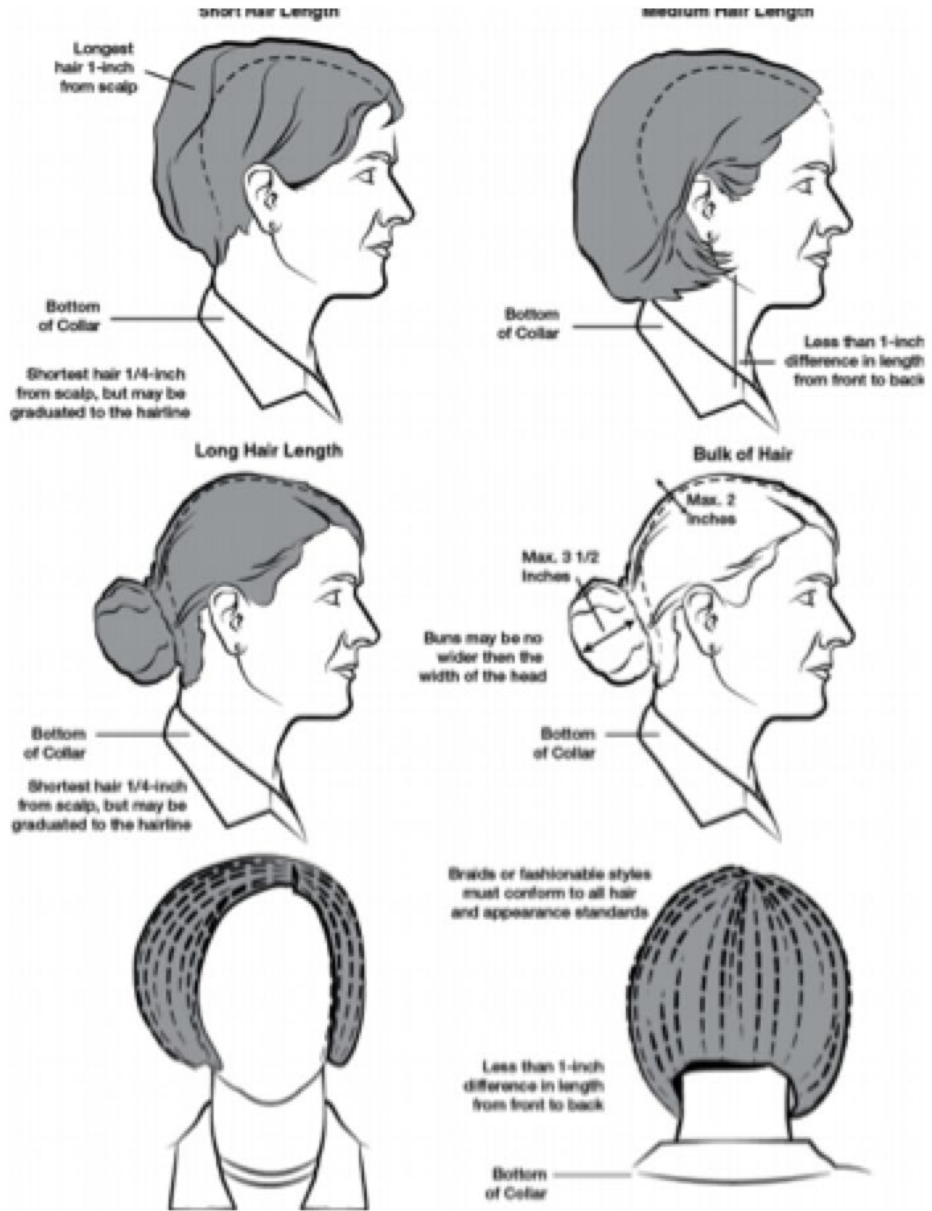

Hairstyle standards Female  
Figure 2-1. Measurement figure (continued)

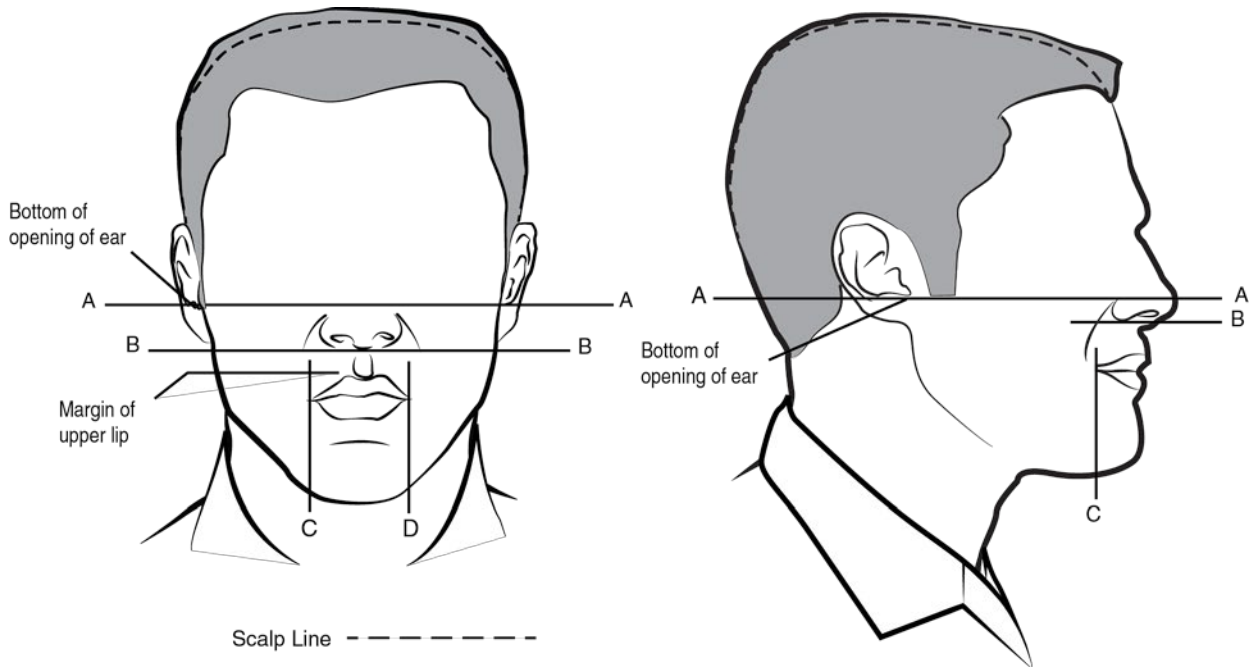

**Hairstyle standards Male**  
**Figure 2-2. Male measurement figure**

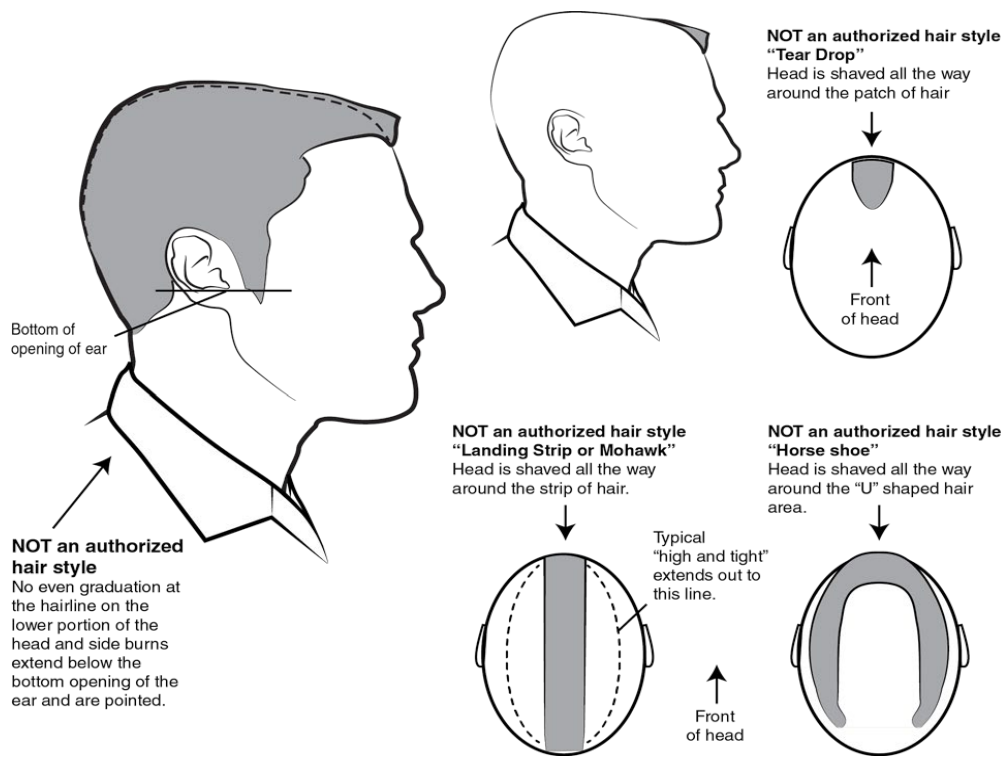

**Figure 2-3. Prohibited male haircuts**

## **2–5. Tattoo, branding, and body mutilation policy**

*Note.* This paragraph is punitive with regard to service members. Violation by service members may result in adverse administrative action and/or charges under the provisions of the MCMJ.

a. Tattoos and brands are permanent markings that are difficult to reverse (in terms of financial cost, discomfort, and effectiveness of removal techniques). Before obtaining either a tattoo or a brand, service members should consider talking to unit leaders to ensure that they understand the defense force tattoo and brand policy. The words tattoo and brand are interchangeable in regard to this policy.

b. The following types of tattoos or brands are prejudicial to good order and discipline and are, therefore, prohibited anywhere on a service member's body:

(1) Extremist. Extremist tattoos or brands are those affiliated with, depicting, or symbolizing extremist philosophies, organizations, or activities. Extremist philosophies, organizations, and activities are those which advocate racial, gender, or ethnic hatred or intolerance; advocate, create, or engage in illegal discrimination based on race, color, gender, ethnicity, religion, or national origin; or advocate violence or other unlawful means of depriving individual rights under the U.S. Constitution, and Federal or State law (see Defense Force Regulation 600–20).

(2) Indecent. Indecent tattoos or brands are those that are grossly offensive to modesty, decency, propriety, or professionalism.

(3) Sexist. Sexist tattoos or brands are those that advocate a philosophy that degrades or demeans a person based on gender.

(4) Racist. Racist tattoos or brands are those that advocate a philosophy that degrades or demeans a person based on race, ethnicity, or national origin.

c. Tattoos or brands, regardless of subject matter, are prohibited on the head, face (except for permanent makeup, as provided in paragraph 2–5b(2)), neck (anything above the t-shirt neckline to include on/inside the eyelids, mouth, and ears), (below the wrist bone), and hands, except service members may have one ring tattoo on each hand, below the joint of the bottom segment (portion closest to the palm) of the finger. Previously documented tattoos on the neck or hands, for which service members have a tattoo validation memorandum, continue to be grandfathered. Accessing applicants must adhere to this same policy.

d. Service members may not cover tattoos or brands with bandages or make up in order to comply with the tattoo policy.

e. Commanders will perform an annual check for new tattoos or brands above the neckline, wrists, and hands. If any unauthorized tattoos are found the service member must be processed in accordance with paragraph 2–5f. Tattoos on the face or head (to include on/inside the eyelids, mouth, and ears) were never authorized locations for tattoos. Service members with tattoos on the head or face must be processed in accordance with paragraph 2–5f, below, unless the service member received a written waiver upon entry into the defense force. Commanders will also conduct a simultaneous check for extremist, indecent, sexist, and racist tattoos. If such tattoos exist, the service member must be processed in accordance with paragraph 2–5f.

f. Commanders will ensure that service members understand the tattoo policy. If a service member has any tattoo or brand that is prohibited under paragraph 2–5b, has any tattoo or brand that is not authorized (such as a tattoo or brand on the face or head or a tattoo on the neck or hand that is not grandfathered), or acquires any new tattoo or brand in violation of paragraph 2–5c, his/her commander will—

(1) Counsel the service member in writing. The DA Form 4856 (Developmental Counseling Form) will state that the service member is not in compliance with AR 670–1, paragraph 3–3 (Defense Force SOP 670–1, paragraph 2–5), and will explain how the tattoo or brand violates the specific prohibition in the policy (for example, the tattoo is extremist because it is a known symbol for a specific hate group; or the new tattoo is in a prohibited location).

(2) Provide the service member with no less than a period of 15 calendar days to seek medical and/or legal advice, fully consider all available options, and respond to the counseling, in writing, by informing the commander that he/she will appeal the finding that the tattoo or brand is in violation of policy, pursue medical procedure(s) to have the tattoo or brand removed (or changed, if applicable), or not have the tattoo or brand removed (or changed, if applicable).

(a) If the service member elects to appeal the finding that the tattoo or brand is in violation of policy, the commander will forward the matter to the first ranking commander in the chain of command for a final determination.

(b) If the service member elects to have the tattoo or brand removed, the commander will counsel the service member on a plan for scheduling the medical procedure(s). Service members will receive a reasonable amount of time to schedule the necessary medical procedure(s) and pay for such procedure(s) (if not available at a military treatment facility). Commanders must also determine if operational requirements will delay the medical procedure(s).



(c) If the service member declines to have the tattoo or brand removed, the commander will counsel the service member in writing. The DA Form 4856 will state that the service member's refusal to remove extremist, indecent, sexist, or racist tattoos or brands anywhere on the body, or refusal to remove any unauthorized tattoo or brand in accordance with paragraph 2–3b constitutes a violation of a lawful order and will result in adverse action. The commander will then initiate administrative separation proceedings.

(d) Company-level commanders will make determinations for current service members that tattoos, or brands comply with this policy. This authority will not be delegated further. If a tattoo or brand is discovered to violate this policy or the service member wishes to appeal the determination, the commander must submit the service member's request to the first ranking commander in the chain of command for decision.

g. Appropriate authorities for accession determinations are listed in subparagraphs (1) through (6), below.

(1) Accessions recruiting battalion commanders, or the recruiting battalion executive officer who has been appointed as acting commander via assumption of command orders in the absence of the battalion commander, will make initial entry determinations for new accessions that tattoos, or brands comply with this policy for defense force service members. This authority will not be delegated further.

(2) Recruiting and retention managers will make initial entry determinations for defense force service members that tattoos, or brands comply with this policy. This authority will not be delegated further.

(3) The commandants of State officer candidate and warrant officer candidate programs will make determinations for candidates, prior to starting the course and prior to commissioning or appointment, that tattoos or brands comply with this policy. This authority will not be delegated further.

h. Determinations for accessions are required when it is reported (either by visual sighting or annotated on the DD Form 2807–1 (Report of Medical History)/DD Form 2808 (Report of Medical Examination)) that a tattoo may be prohibited per paragraph 2–3b. Determinations will be fully documented, in writing, and will include a description of all existing tattoos and their location on the body. The service member or applicant will receive a copy of all documentation. Unless otherwise directed by the DCS, S1, these determinations are final. If a tattoo is discovered to violate this policy after an initial determination has been documented, commanders must submit requests for an exception to policy or for discharge through the service member's chain of command for approval. Appeals to the decision will be forwarded to the DCS, S1 for decision.

i. Exceptions to policy for accessing applicants not meeting the criteria outlined in paragraph 2–3c must be approved by the Director of Military Personnel Management, DCS, S1. Such exceptions must be documented and uploaded into the service member's Defense Force Military Human Resource Record (DMHRR) upon accession into the Defense Force. Any previous delegation of approval authority for exception to policy for accessing applicants is revoked. This authority will not be further delegated.

j. Service members are prohibited from any unauthorized form of body mutilation, which is the willful mutilation of the body or any body parts in any manner. This prohibition does not include authorized medical alterations performed at a medical treatment facility or cosmetic, reconstructive, or plastic surgery procedures the commander normally approves. Examples of unauthorized body mutilation include, but are not limited to, tongue bifurcation (splitting of the tongue), ear gauging (enlarged holes in the lobe of the ear that are greater than 1.6mm), unnatural shaping of teeth, ear pointing (or elfing), scarification (cutting to create intentional scarring), or body modifications for the purpose of suspension (hanging by body hooks). Service members who entered the defense force with approved body mutilation before 31 March 2021 may request an exception to policy from DCS, S1. See DA Pam 670–1 for processing guidance.

## **2–6. Jewelry**

*Note.* This paragraph is punitive with regard to service members. Violation by service members may result in adverse administrative action and/or charges under the provisions of the MCMJ.

a. Service members may wear a wristwatch, a wrist religious or identification bracelet, and a total of two rings (a wedding set is considered one ring) with defense force uniforms, unless prohibited by the commander for safety or health reasons. Service members may also wear one activity tracker, pedometer, or heart rate monitor. Any jewelry or monitors service members wear while in uniform or civilian clothes on duty must be conservative. Bracelets are limited to medical alert bracelets, missing in action, prisoner of war, killed in action (black or silver color only), and religious bracelets similar in size and appearance to identification bracelets. Service members are authorized to wear only one item on each wrist while in uniform or in civilian clothes on duty. In addition to the one item (watch or identification bracelet) authorized to be worn on each wrist, service members may wear an activity tracker, pedometer, or heart rate monitor. Male service members may wear a conservative tie tack or tie clasp with a necktie. Female service members may wear earrings as described in paragraph 2–6d.

b. No jewelry, other than that described in paragraphs 2–6a or 2–6d, below, can appear exposed while in uniform,

or in civilian clothes on duty. Additional guidance on religious items is described in paragraphs 2–17 and 2–18. Pens and/or pencils of any color may be worn exposed in the pen/pencil slots on any uniform with such slots.

c. Attaching, affixing or displaying objects, articles, jewelry, or ornamentation to, through, or under their skin, tongue, or any other body part is prohibited. This applies to all service members on or off duty. The only exception is the wear of earrings consistent with paragraph 2–6d. (The term “skin” is not confined to external skin but includes the tongue, lips, inside the mouth, and other surfaces of the body not readily visible.)

d. Females only are authorized to wear earrings with the service, dress, mess, and evening mess uniforms.

(1) Earrings may be screw-on, clip-on, or post-type earrings in gold, silver, white pearl, or diamond. The earrings will not exceed 6 mm or 1/4 inch in diameter, and they must be unadorned and spherical. When worn, the earrings will fit snugly against the ear. Females may wear earrings only as a matched pair, with only one earring per ear lobe.

(2) Females are not authorized to wear earrings with any Class C uniform (combat, utility, garrison culinary, physical fitness, field, or organizational).

(3) When in civilian clothes on duty, female service members must comply with the specifications listed in subparagraph (1), above, when wearing earrings, unless otherwise authorized by the commander. Male service members may not wear earrings when in civilian clothes on duty.

(4) When male and female service members are not in uniform and off duty, earring wear is not restricted as long as the earrings do not create or support ear gauging (enlarged holes in the lobe of the ear, greater than 1.6mm).

e. Ankle bracelets, toe rings, necklaces (other than those described in paragraph 2–6a), faddish (trendy) devices, medallions, amulets, and personal talismans or icons are not authorized for wear while in uniform or in civilian clothes on duty.

f. The use of gold caps, platinum caps, or caps of any unnatural color or texture (permanent or removable) for purposes of dental ornamentation is prohibited. Teeth, whether natural, capped, or veneered, will not be decorated with designs, jewels, initials, or similar ornamentation. Unnatural shaping of teeth for nonmedical reasons is prohibited. Commanders may consider waivers for permanent caps that were applied prior to the effective date of this SOP. Such waivers must be approved by the first ranking commander in the chain of command and documented in an official memorandum, which must be uploaded to the service member’s electronic personnel record. A picture of the permanent caps must be appended as an enclosure to the memorandum.

## **2–7. Wear of defense force uniform at national, regional, and local events**

*Note.* This paragraph is punitive with regard to service members. Violation by service members may result in adverse administrative action and/or charges under the provisions of the MCMJ.

a. When defense force participation in a public event has been approved, commanders are responsible for determining the appropriate uniform for the event. Generally, protocol standards dictate standards of dress. For instance, when an invitation calls for business attire, the appropriate defense force uniform is the service or dress uniform. However, in some instances, the Class C or utility uniform may be appropriate. Commanders should make use of their protocol or other appropriate supporting staff for a decision regarding the appropriate uniform.

b. Commanders should use their discretion and consider the following when determining the appropriate uniform for the event:

- (1) The nature and location of the event (for example, on or off-post).
- (2) Whether the event is open to the public or not.
- (3) The solemnity of the event.
- (4) Who is being recognized at or by the event (is the event recognizing current service members or veterans).
- (5) Who is hosting the event.
- (6) Who is attending the event.
- (7) Whether the media will be present.

c. When attire is listed as “duty uniform,” the activities undertaken drive the appropriate uniform. “Duty uniform” does not necessarily indicate Class C or utility uniform wear. When “duty” is listed as the uniform for an event, commanders need to exercise good judgment for participants and attendees.

d. If an event recognizes the service and sacrifice of service members for named operations, then the Class C or Army combat uniform (ACU) may be appropriate. If the event recognizes the shared sacrifice of our veterans on Veteran’s Day, then the service uniform is appropriate. In all cases, the defense force is on display. Commanders are expected to recognize the difference and prescribe a uniform appropriate for an event.

e. When commanders are in doubt regarding the appropriate uniform, they should seek guidance from their higher headquarters and/or the appropriate public affairs or protocol office.

## **2–8. Uniform appearance and fit.**

### **a. Appearance.**

(1) All personnel will maintain a high standard of professional dress and appearance. Uniforms will fit properly; the proper fitting of uniforms is provided in DA Pam 670–1. Personnel must keep uniforms clean, serviceable, and roll-pressed, as necessary. Service members must project a military image that leaves no doubt that they live by a common military standard and uphold military order and discipline.

(2) Consider the following when wearing items on uniforms:

(a) Keys or key chains will not be attached to the uniform on the belt, belt loops, or waistband, unless they are not visible (to include making a bulky appearance under the uniform). When authorized by the commander, service members may attach visible keys or key chains to the uniform when performing duties such as charge of quarters, armorer, duty officer or noncommissioned officer (NCO), or other similar duties.

(b) Service members may wear an electronic device on the belt, belt loops, or waistband of the uniform. Only one electronic device (for example, cell phone) may be worn. The body of the device may not exceed the size of a government-issued electronic device, and the device and carrying case must be black; no other colors are authorized. If security cords or chains are attached to the device, service members will conceal the cord or chain from view. Other types of electronic devices are not authorized for wear on the uniform, unless medically prescribed. If the commander issues and requires the use of other electronic devices in the performance of duties, the service member will carry them in the hand, pocket, briefcase, purse, bag, or some other carrying container.

(c) Service members will not wear keys, key chains, or electronic devices on the uniform when the commander determines such wear is inappropriate (such as in formation or during parades or ceremonies).

(d) Service members will not walk while engaged in activities that would interfere with the hand salute and greeting of the day or detract from a professional image. Examples include, but are not limited to, walking while eating, using electronic devices, or smoking cigarettes, cigars, or pipes. Service members are not authorized to wear wireless or non-wireless devices/earpieces while wearing defense force uniforms, except for headphones as prescribed below. Hands free devices while operating a personal, commercial, or military vehicle (to include a motorcycle or bicycle) are allowed if not otherwise prohibited by policy or law in accordance with AR 385–10.

(3) Unless the unit or installation commander otherwise prohibits, service members may use headphones, including wireless or non-wireless devices and earpieces, in uniform while performing individual physical training in indoor gyms or fitness centers. Service members may not wear headphones while taking the defense force Duty Level Qualification Test (DLQT). Service members may not wear headphones beyond the permitted area in any manner, including around the neck or attached to the uniform. Headphones will be conservative and discreet. Ear pads will not exceed 1 1/2 inches in diameter at the widest point. Service members may wear electronic devices, such as music players or cell phones, as prescribed above; service members may also wear a solid black armband to store and carry electronic devices in the gym or fitness center. Service members may not wear the armband beyond the permitted area.

(4) While in uniform, personnel will not place their hands in their pockets, except momentarily to place or retrieve objects. Service members will keep uniforms buttoned, zipped, and snapped. They will ensure that metallic devices such as metal insignia, belt buckles, and belt tips are free of scratches and corrosion and properly polished or properly subdued, as applicable. Service members will ensure all medals and ribbons are clean and not frayed. Personnel will keep boots and shoes cleaned and/or shined, as appropriate. Service members will replace insignia when it becomes unserviceable or no longer conforms to standards.

(5) Lapels and sleeves of service/dress and mess coats and jackets will be roll pressed, without creasing. Skirts will not be creased. Trousers, slacks, and the sleeves of shirts and blouses will be creased. Personnel are not authorized to sew military creases into the uniform.

(6) Although some uniform items are made of wash-and-wear materials, or are treated with a permanent-press finish service members may need to press these items to maintain a neat, military appearance. However, before pressing or roll pressing uniform items, service members should read and comply with care instruction labels attached to the items. Use of starch, sizing, and any process that involves dry-cleaning or steam pressing will adversely affect the treatments and durability of the wash-and-wear uniforms and is not authorized. See DA Pam 670–1 regarding specific guidance pertaining to each uniform.

b. Fit. Instructions for fit of uniforms are contained in DA Pam 670–1.

c. Additional policy. Uniform guidance for service members who are breastfeeding/pumping can be found in both AR 670–1 and DA Pam 670–1.

## **2-9. Required or prohibited wearing of the defense force uniform.**

*Note.* This paragraph is punitive with regard to service members. Violation by service members may result in adverse administrative action and/or charges under the provisions of the MCMJ.

a. All personnel will wear a defense force uniform when on duty, unless granted an exception by the commander to wear civilian clothes. The following personnel may grant exceptions:

- (1) The defense force commander or designee.
- (2) Heads of defense force staff agencies or HQDF principal officials.
- (3) Commanders of battalions, companies and detachments.
- (4) Heads of Michigan Department of Military and Veterans Affairs (DMVA) agencies.

b. Personnel on official travel and traveling by commercial travel means may wear the service uniform, the ACU, or appropriate civilian attire, unless restricted by the commander.

c. Service members may wear optional uniform items as prescribed in this SOP and DA Pam 670

1. All uniform combinations are authorized for year-round wear. However, service members should use appropriate discretion based upon weather conditions and duties. Wearing combinations of uniform items not prescribed in this SOP, DA Pam 670-1, or other authorization documents approved by HQDF is prohibited. Commanders will not prescribe seasonal wear dates for uniform items but may prescribe uniform(s) based on safety reasons (for example, for extreme cold or hot weather based on temperature).

d. Wearing a combination of civilian and military clothing is prohibited, unless prescribed in this SOP or directed by the defense force commander.

e. Bags, handbags, purses, and backpacks are authorized, but must adhere to the following criteria:

(1) Hand carried bags will be conservative and professional in appearance. Bags (to include civilian gym bags, civilian backpacks, or other similar civilian bags) must be carried only in the hand. DA Pam 670-1 provides additional descriptions and wear occasions for handbags.

(2) If service members choose to wear a shoulder bag while in uniform, the bag must be black or match the camouflage pattern uniform being worn and may not have any commercial logos. The contents of the bag may not be visible; therefore, see-through plastic or mesh bags are not authorized. Service members may carry authorized bags by hand, on one shoulder using a shoulder strap, or over both shoulders using both shoulder straps. Service members may not wear a shoulder bag in such a manner that the strap is draped diagonally across the body, with the bag resting on the hip opposite the shoulder holding the strap.

(3) Commanders may prescribe the wear of organizational issue rucksacks in garrison and field environments.

f. Service members may continue to wear issued uniform items changed in design or material as long as the item remain in serviceable condition, unless specifically prohibited by this SOP or DA Pam 670-1.

g. Civilian clothing is considered appropriate attire for individuals who are participating in civilian outdoor activities, such as volksmarches, orienteering, or similar activities. Service members who are spectators at these activities may wear the service uniform. Service members who are participating in, or observing these events, are not authorized to wear utility or field uniforms. However, commanders of participating units or of those units that provide support personnel (such as medical and traffic control personnel) may prescribe appropriate uniforms, to include utility or organizational uniforms, if warranted by the occasion, weather conditions, or activity.

h. Service members may wear experimental uniform items while actively engaged in an experimental uniform test program approved by Headquarters, Defense Force Training and Doctrine Command; Defense Force Uniform Board, HQDF; DMVA. Service members will not wear experimental items after completion of the test, unless such wear has been approved by HQDF.

i. Technicians, who are also members of the state military establishment, will wear the appropriate duty uniform while engaged in their civil service status.

j. Wearing defense force uniforms is prohibited in the following situations:

(1) In connection with the furtherance of any political or commercial interests, or when engaged in off duty civilian employment.

(2) When participating in public speeches, interviews, picket lines, marches, rallies, or public demonstrations, except as authorized by the first O-5 in the chain of command.

(3) When attending any meeting or event that is a function of, or is sponsored by, an extremist organization.

(4) When wearing the uniform would bring discredit upon the defense force, as determined by the commander.

(5) When specifically prohibited by defense force SOPs.

k. Service members will wear headgear with the defense force uniform, except under the following circumstances:

(1) Headgear is not required if it would interfere with the safe operation of military vehicles. Wearing military headgear is not required while in or on a privately owned vehicle (to include a motorcycle, bicycle, or convertible

automobile), a commercial vehicle, or on public conveyance (such as a subway, train, plane, or bus).

(2) Service members will not wear headgear indoors, unless under arms in an official capacity, or when directed by the commander, such as for indoor ceremonial activities.

(3) Male and female service members are not required to wear headgear to evening social events (after retreat) when wearing the Army service and dress uniforms.

(4) Service members will carry their headgear, when it is not worn, in their hands while wearing service and dress uniforms. Service members are authorized storage of the headgear, when it is not worn, in the Class C uniform cargo pockets, if applicable. Service members must fold the headgear neatly so as not to present a bulky appearance. They may also elect to store it at the small of the back, with the bill tucked in the belt, provided there is no bulky appearance, and the headgear remains hidden from view. Service members will not attach headgear to the uniform or hang it from the belt.

## **2-10. Distinctive uniforms and uniform items**

a. For purposes of applying the provisions of this SOP, the following uniform items are distinctive and will not be sold to or worn by unauthorized personnel:

(1) All defense force headgear, when worn with insignia.

(2) Badges and tabs (identification, marksmanship, combat, and special skill).

(3) Uniform buttons (defense force).

(4) Decorations, service medals, service and training ribbons, and other awards and their appurtenances.

(5) Insignia of any design or color that the defense force has adopted.

b. Individuals will remove all distinctive items before disposing of unserviceable uniform items.

c. Specific instructions regarding uniforms and uniform items are adapted from DA Pam 670-1.

## **2-11. Civilian clothing**

a. Civilian clothing is authorized for wear when off duty, unless the wear is prohibited by the senior commander. Commanders down to unit level may restrict the wear of civilian clothes by those service members who have had their pass privileges revoked. Within the confines of a military base or a DOD/DMVA installation, civilian clothing will be worn subject to local SOPs.

b. When on duty in civilian clothes or off duty and outside of their personal dwelling, defense force personnel will present a professional image that does not detract from the profession, unless specifically exempted by the commander for specific mission requirements.

c. Service members are associated and identified with the defense force in and out of uniform, and when on or off duty. Therefore, when civilian clothing is worn, service members will ensure that their dress and personal appearance are commensurate with the high standards traditionally associated with military service. Commanders are charged with determining and publishing the local civilian clothing policy. When on a military installation, civilian headgear will be removed indoors in accordance with established norms.

d. When civilian clothing has been authorized by competent authority for wear in a duty status in lieu of a uniform, the civilian clothing will be of the same comparable degree of formality as the uniform prescribed for such duty. Standards of dress and appearance will be conservative and meet the same high standards established for personnel in uniform.

e. The wear of clothing articles not specifically designed as headgear (for example, bandannas, do rags) are prohibited while on duty.

f. No part of a prescribed uniform, except those items not exclusively military in character, may be worn with civilian clothing.

g. Uniform items authorized for wear with civilian clothing by males are restricted to the gold cufflinks, studs, tie bar, mourning band, footwear, socks, gloves, undergarments, black bowtie, wool scarf, all-weather coat, fleece caps, and physical training uniforms.

h. Uniform items authorized for wear with civilian clothing by females are restricted to the white shirt without insignia of grade, undergarments, footwear, gloves, handbag, clutch purse, wool scarf, all-weather coat, fleece caps, and physical training uniforms.

i. Uniform items that have been declared obsolete may be worn with civilian clothing provided such items contain no distinctive insignia or buttons.

## **2-12. Eyeglasses, sunglasses, and contact lenses**

*Note.* This paragraph is punitive with regard to service members. Violation by service members may result in

adverse administrative action and/or charges under the provisions of the MCMJ.

a. Eyeglasses and sunglasses.

(1) Conservative civilian prescription eyeglasses are authorized for wear with all uniforms.

(2) Conservative prescription and nonprescription sunglasses are authorized for wear when in a garrison environment, except while indoors. Individuals who are required by medical authority to wear sunglasses for medical reasons, other than refractive error, may wear them, except when health or safety considerations apply. Commanders may authorize sunglasses in formations or field environments, as appropriate.

(3) Eyeglasses or sunglasses that are trendy or have lenses or frames with conspicuous initials, designs, or other adornments are not authorized for wear. Service members may not wear lenses with extreme or trendy colors, which include, but are not limited to, red, yellow, blue, purple, bright green, or orange. Lens colors must be traditional gray, brown, or dark green shades. Personnel will not wear lenses or frames that are so large or so small that they detract from the appearance of the uniform. Personnel will not attach chains or ribbons to eyeglasses. Eyeglass restraints (to include bands) are authorized when required for safety purposes. Personnel will not hang eyeglasses or eyeglass cases on the uniform and may not let glasses hang from eyeglass restraints down the front of the uniform. Glasses may not be worn on top of the head at any time.

(4) Service members are authorized to wear ballistic spectacle eye protection issued by the Army or any authorized civilian or commercially available substitute, including lens colors or logos that do not comply with paragraph 2-12a(3), above, in garrison or field environments unless otherwise directed by their chain of command. See the Army Combat Readiness Center for a list of currently approved protective eyewear as a reference.

b. Restrictions on contact lenses. Tinted or colored contact lenses are not authorized for wear with the uniform. The only exception is for opaque lenses that are prescribed medically for eye injuries. Clear lenses that have designs on them that change the contour of the iris are not authorized for wear with the uniform. Contact lenses may be restricted by the commander for safety or mission requirements.

## **2-13. Identification tags and security identification badges**

a. Identification tags. Wearing identification tags will be governed by policies adopted from both AR 600-8-14 and DA Pam 600-8-14.

(1) Service members will wear identification tags at all times while on duty in uniform unless otherwise directed by the commander.

(2) Personnel will wear identification tags around the neck, except when safety considerations apply (such as during physical training).

b. Security identification badges. In restricted areas, commanders may prescribe wearing security identification badges, in accordance with applicable defense force SOPs. Personnel will not wear security identification badges outside the area for which they are required. Personnel will not hang other items from the security identification badge(s). The manner of wear will be determined by the organization that requires wearing the badges.

## **2-14. Personal protective or reflective clothing**

a. Protective headgear. Service members are authorized to wear commercially designed protective headgear while in uniform when operating motorcycles, bicycles, or other similar vehicles and are required to do so when installation SOPs mandate such wear. Personnel will remove protective headgear and wear authorized defense force headgear upon dismounting from the vehicle.

b. Protective and/or reflective clothing. Service members may wear protective and/or reflective outer garments with uniforms when required per AR 385-10, when safety considerations make it appropriate, or when authorized by the commander.

## **2-15. Organizational protective or reflective clothing**

When required by AR 385-10 or when safety considerations apply, commanders may require service members to wear organizational protective or reflective items, or other occupational health or safety equipment, while in uniform (such as during physical fitness training). If required by law, DOD or Army policy, DMVA guidance, or defense force SOP, commanders will furnish necessary protective or reflective clothing to service members at no cost.

## **2-16. Heraldic items**

a. The heraldic items listed below are authorized for purchase and possession per AR 672-8. Variations from the prescribed specifications for these heraldic items are not permitted without prior approval.

(1) All insignia approved by DMVA and/or HQDF.

- (2) Appurtenances and devices for attachment to decorations, service medals, and ribbons.
- (3) Miniature replicas of decorations, service medals, and ribbons.
- (4) Oversized replicas of decorations and service medals for grave markers only. These replicas must be at least twice the size prescribed for the decoration or service medal.
- (5) Ribbons pertaining to decorations and service medals.
- (6) Unit award emblems, fourragères, and the orange lanyard.
- (7) Combat, special skill, and marksmanship badges, including miniatures and dress miniatures.
- (8) Identification badges.
- (9) Rosettes and lapel buttons.
- b. The heraldic items listed below are not authorized for purchase.
  - (1) Medal of Honor.
    - (a) Medal of Honor service ribbon.
    - (b) Medal of Honor rosette.
    - (c) Medal of Honor flag.
  - (2) Items incorporating designs or the likeness of decorations, service medals, and service ribbons.
- c. The possession, wear, and other uses of heraldic items are addressed below.
  - (1) The possession of any of the items listed in paragraph 2–16a, above, or elsewhere in this SOP is authorized. Wearing of any HQDF-prescribed decoration, service medal, badge, service ribbon, lapel button, or insignia by persons not authorized to do so, or the use of such items to defraud or misrepresent their identification or status, is prohibited. Persons violating this provision are subject to punishment under the provision of 18 USC 701, 18 USC 704, or the MCMJ.
    - (2) No organization, society, or other group of persons may use any of the articles or imitations specified in paragraph 2–16a, above or elsewhere in this SOP without written approval of the TAG or his designee the defense force commander.
      - d. The incorporation of designs or likenesses of approved designs in commercial articles is addressed below.
        - (1) Defense force policy restricts the use of its military designs. The manufacture of articles for public sale that incorporate designs or likenesses of decorations, service medals, service ribbons, and lapel buttons is prohibited. Certain designs or likenesses of insignia, such as badges or organizational insignia, may be incorporated in articles manufactured for sale, provided that permission has been granted, in writing, as specified below.
        - (2) The defense force commander is responsible for granting permission for the incorporation of certain defense force designs in articles manufactured for sale to the public.

## **2–17. Religious jewelry, apparel, or articles**

Religious jewelry, apparel, or articles (hereafter referred to as religious items) may be worn while in uniform if they are “neat and conservative.” Except as noted in the following paragraphs, service members may not wear religious items that do not meet the standards of this SOP, unless a religious accommodation is granted in accordance with AR 600–20.

- a. In accordance with 10 USC 774, service members may wear items of religious apparel while in uniform, except where the items would interfere with the performance of military duties, or the items are not neat and conservative.
  - (1) For religious accommodation purposes only, neat and conservative items of religious apparel are those that—
    - (a) Are discreet, tidy, and not dissonant or showy in style, size, design, brightness, or color.
    - (b) Do not replace or interfere with the proper wear of any authorized article of the uniform.
    - (c) Are not temporarily or permanently affixed or appended to any authorized article of the uniform.
  - (2) Factors used to determine if an item of religious apparel interferes with military duties include, but are not limited to, whether or not the item—
    - (a) Impairs the safe and effective operation of weapons, military equipment, or machinery.
    - (b) Poses a health or safety hazard to the service member wearing the religious apparel and/or others.
    - (c) Interferes with the wear or proper function of special or protective clothing or equipment.
    - (d) Otherwise impairs the accomplishment of the military mission.
- b. Service members may wear religious items that are not visible or apparent when in duty uniform, provided they do not interfere with the performance of the service member’s military duties or interfere with the proper wearing of any authorized article of the uniform. Examples of such items include (but are not limited to) religious jewelry worn under the duty uniform or copies of religious symbols or writing carried by the individual in wallets or pockets. If religious items are worn on a necklace, the visible portion of the chain may be no wider than the identification tag chain.
- c. Religious jewelry that is visible or apparent when in duty uniform is authorized if it meets the standards for wear

of jewelry in paragraph 2–6. Jewelry bearing religious symbols or worn for religious reasons will not be singled out; all wear and appearance standards will apply equally to religious and non-religious jewelry.

d. Religious items that do not meet the standards of AR 670–1 may be worn by service members in uniform while they are present at a worship service, rite, or other ritual distinct to a faith or denominational group. Commanders may, for operational or safety reasons, limit the wear of non-subdued items of religious apparel during services conducted in the field based on military necessity.

e. Chaplains may wear religious attire as described in this SOP, DA Pam 670–1, GTA 50–9–9, and AR 165–1 in the performance of religious services and other official duties as required. Commanders may not prohibit chaplains from wearing religious symbols that are part of the chaplain’s duty uniform.

f. Religious headgear may be worn while in uniform if the headgear meets the following criteria:

(1) The religious headgear is subdued in color (generally black, brown, green, dark or Navy blue, or a combination of these colors). The headgear will not be patterned, except that a service member wearing the ACU may wear headgear in a camouflage pattern matching the uniform.

(2) The religious headgear is of a style and size that can be completely covered by standard military headgear.

(3) The religious headgear bears no writing, symbols, or pictures.

(4) Wear of the religious headgear does not interfere with the wear or proper functioning of protective clothing or equipment.

(5) Religious headgear that meets these criteria is authorized irrespective of the faith group from which it originates.

(6) Religious headgear will not be worn in place of military headgear under circumstances when the wear of military headgear is required (for example, when the service member is outside or required to wear headgear indoors for a special purpose).

## **2–18. Religious accommodations**

*Note.* The following uniform and grooming standards apply only to service members with a religious accommodation request approved in accordance with Defense Force SOP 600–1 for one or more of the listed practices.

a. *Hijab (Head Scarf).*

(1) An accommodated service member may wear a hijab (head scarf) made of a subdued material in a color that closely resembles the assigned uniform (generally black, brown, green, tan, or navy blue as appropriate). The material will be free of designs or markings, except that a service member wearing the ACU may wear a hijab in a camouflage pattern matching the uniform. When directed by a commander, the service member may be required to wear a hijab made of fire-resistant material.

(2) The hijab will be worn in a neat and conservative manner that presents a professional and well-groomed appearance. The hijab must be closely fitted to the contours of the head and neck and may not cover the eyebrows, eyes, cheeks, nose, mouth, or chin. The bottom edges of the hijab will be tucked under the service member's uniform top and all required headgear will still be worn.

(3) Hair underneath the hijab must be worn in a hairstyle authorized for the service member in paragraph 2–4. The bulk of the service member's hair and hijab may not impair the ability to wear required headgear, the Advanced Combat Helmet, or other protective equipment; impede the ability to operate an assigned weapon, military equipment, or machinery; or interfere with the ability to perform the service member's military duties.





Figure 2-4. Hijab

---

b. *Beard.*

(1) Beards (which include facial and neck hair) must be maintained to a length not to exceed two inches when measured from the bottom of the chin. Beard hair longer than 2 inches must be rolled and/or tied to achieve the required length. Beards must be worn in a neat and conservative manner that presents a professional appearance. Service members may use styling products to groom or hold the beard in place but may not use petroleum-based products if wearing a protective mask during training. The bulk of a service member's beard may not impair the ability to operate an assigned weapon, military equipment, or machinery.

(2) A mustache worn with a beard may extend sideways beyond the corners of the mouth to connect with the beard but must be trimmed or groomed to not cover the upper lip.

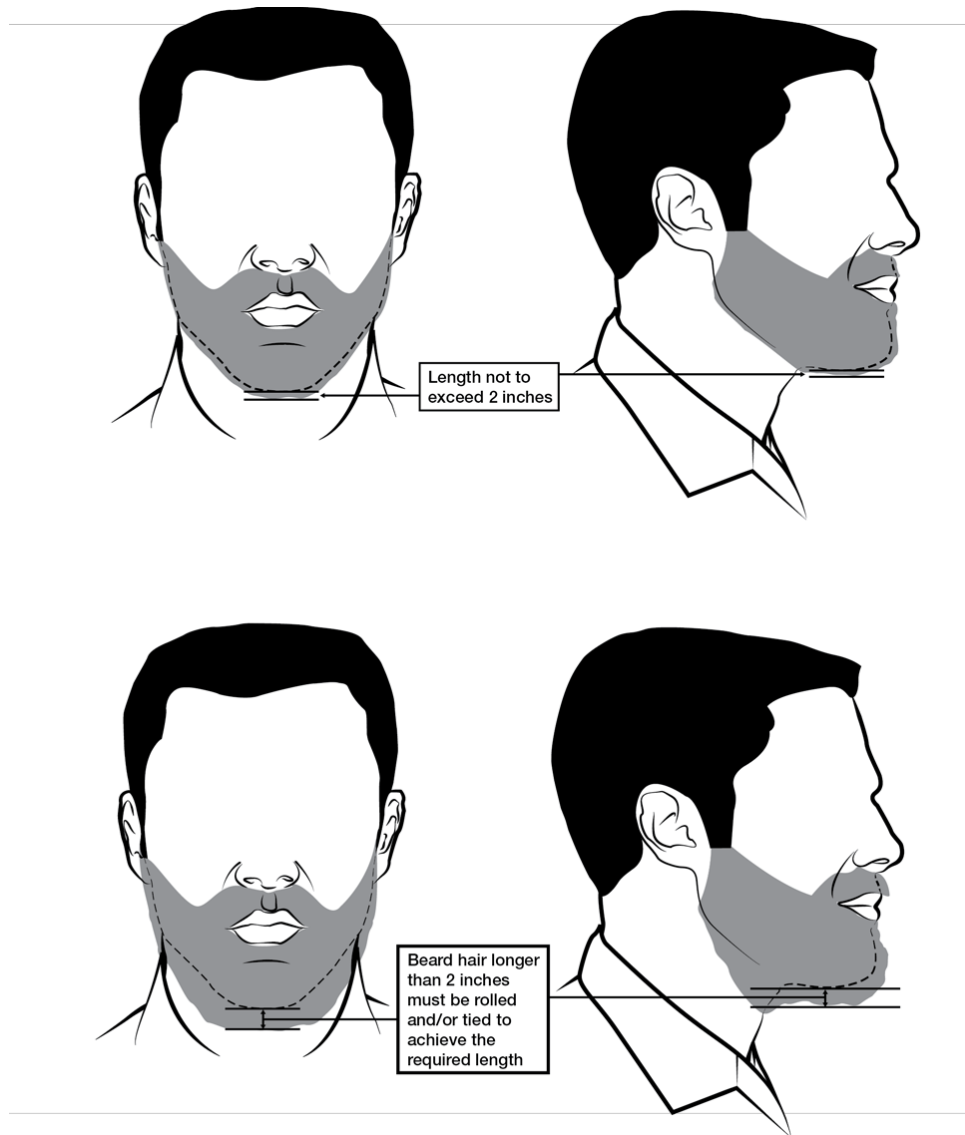

**Figure 2-5. Beard**

*c. Turban and under-turban.*

(1) An accommodated service member may wear a turban (or under-turban or patka, as appropriate) made of a subdued material in a color that closely resembles the headgear for an assigned uniform. Commanders may designate conditions where the under-turban will be worn instead of the turban. The turban or under-turban will be worn in a neat and conservative manner that presents a professional and well-groomed appearance. The material will be free of designs or markings, except that a service member wearing the ACU may wear a turban or under-turban in a camouflage pattern matching the uniform. When directed by a commander, the service member may be required to wear an under-turban made of fire-resistant material.

(2) Unless duties, position, or assignment require a service member to wear the ACH or other protective headgear, service members granted this accommodation are not required to wear military headgear in addition to the turban or under-turban. Rank will be displayed on the turban or under-turban when worn in circumstances where military headgear is customarily worn and removed in circumstances where military headgear is not customarily worn, such as indoors or in no-hat/no-salute designated areas.

(3) Hair worn under the turban or under-turban is not subject to AR 670-1 standards but may not fall over the ears or eyebrows or touch the collar while in uniform. When the service member is wearing an ACH or other protective headgear with the under-turban, the bulk of the hair will be repositioned or adjusted to ensure proper fit.

---

Figure 2-6. Turban

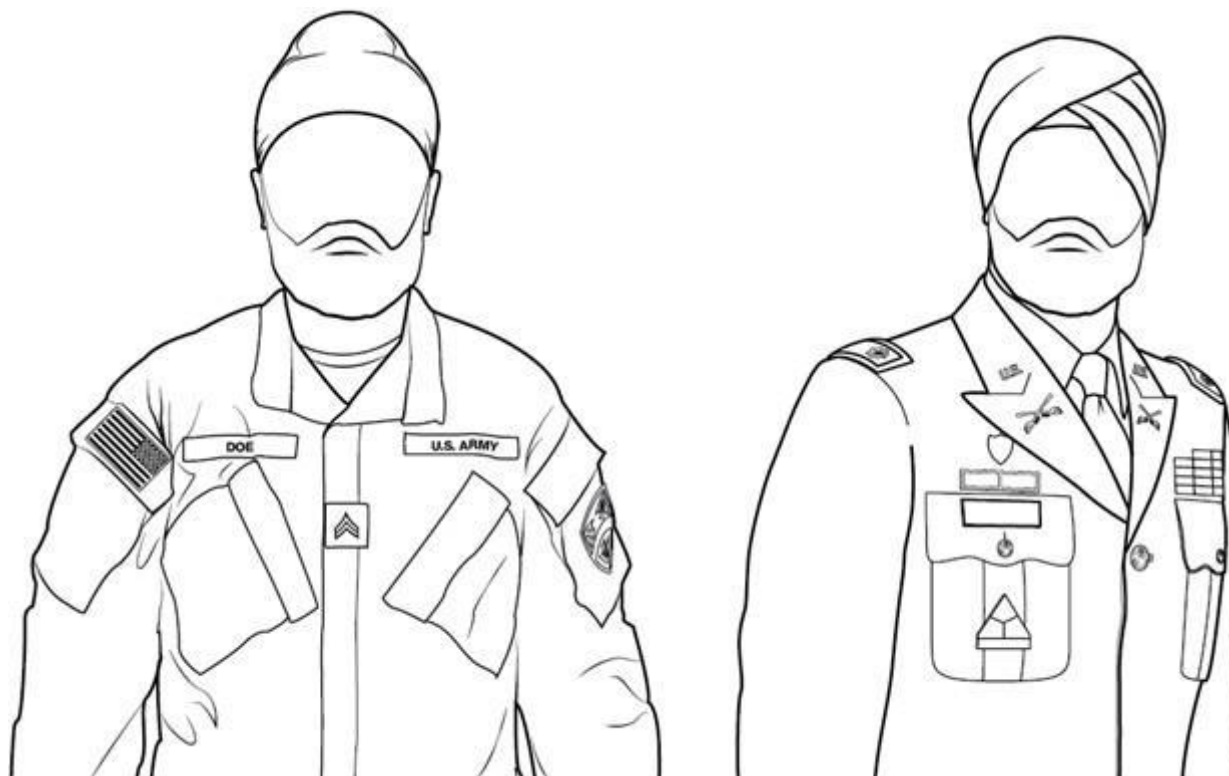

**2-19. Walking Aids**

Walking aids such as a cane, walker, walking stick, knee scooter, and all other mobility equipment is prohibited while in uniform unless authorized by Defense Force medical personnel.

## **Chapter 3 Defense Force Uniforms**

### **3–1. Uniforms**

The defense force is a uniformed service of the State of Michigan. As an element of that service, the wearing of an approved uniform is essential for identification and function. The US Army, through regulation (AR 670–1), provides guidance for uniforms authorized for wear by members of State Defense Forces. Additional guidance impacting the wearing of uniforms, from both the Adjutant General of Michigan and the defense force commander, is provided in this SOP.

### **3–2. Approved Uniforms**

The following uniforms are approved for wear by defense force personnel:

- a. Class A Army Service Uniform / Army Green Service Uniform (ASU/AGSU)
- b. Class B Army Service Uniform / Army Green Service Uniform (ASU/AGSU)
- c. Class C Uniform:
  - (1) Army Combat Uniform (ACU)
  - (2) Defense Force Garrison Culinary Uniform
  - (3) Defense Force Maternity Uniform
  - (4) Defense Force Physical Fitness Uniform (DPFU)
- d. Class D Uniform (Alternate) Uniform (as required by Defense Force SOP 600–9)

## **Chapter 4 Combat Uniform**

### **4–1. Authorization for wear**

The combat uniform is authorized for year-round duty wear by service members when prescribed by the commander. Some combat uniforms are classified as utility uniforms, while others are designed for a specific function. See DA Pam 670–1 for uniforms currently classified as combat uniforms.

### **4–2. Occasions for wear**

- a. All-purpose wear. Some versions of the combat uniform are not intended for wear as an all-purpose uniform. The combat uniform is designed to be worn under body armor.
- b. Approved wear.
  - (1) The combat uniform is prescribed for year-round wear for all service members, unless otherwise directed by the commander. Service members may wear the combat uniform off-post, unless prohibited by the commander.
  - (2) Service members may wear the combat uniform for commercial travel per paragraph 2–9b through c.
  - (3) Service members may roll-up the sleeves on the ACU. When service members wear the sleeves of the ACU coat rolled up, the camouflage pattern will remain exposed. Personnel will roll sleeves neatly above the elbow but no more than three inches above the elbow. Upon approval of the commander and only during field training exercises, the sleeves may be down and cuffed inside the coat.
- c. Restrictions on wear.
  - (1) Personnel may not wear the combat uniform in off-post establishments that primarily sell alcohol for consumption on the premises. If the off-post establishment sells alcohol and food for consumption on the premises, service members may not wear the combat uniform if their activities in the establishment center on the drinking of alcohol.
  - (2) The combat uniform is not normally considered appropriate for social or official functions off the installation, such as memorial services, funerals, weddings, inaugurations, patriotic ceremonies, and similar functions.
  - (3) Commanders may further restrict wear of the combat uniform per paragraph 2–5c.
- d. Organizational and equipment. The commander may prescribe organizational and individual equipment items in accordance with CTA 50–900 when the combat uniform is prescribed for parades, reviews, and ceremonies.



### 5-3. Accessories

The following accessories are normally worn with the combat uniform:

- a. Army combat shirt.
- b. Bags, backpacks, and handbags in accordance with AR 670-1.
- c. Beret (see para 10-4).
- d. Chaplain's apparel (chaplains only) (see para 10-7).
- e. Coat, Extended Cold Weather Clothing System (ECWCS) Generation III (see fig 5-2).
- f. Fleece cap.
- g. Gloves, utility.
- h. Hat, drill sergeant.
- i. Military police (MP) accessories.
- j. Neck gaiter, optional purchase or OCIE.
- k. OCIE, as determined by the commander in accordance with common table of allowances (CTA) 50-900 or CTA 8-100 (medical personnel).
- l. Personal hydration systems.
- m. Scarf, utility.
- n. Undergarments.



Figure 5-2. Extended Cold Weather Clothing System coat

#### **5-4. Materials**

- a. The fabric of the ACU is 50-percent nylon and 50-percent cotton.
- b. The fabric of the flame-resistant (FR) combat uniform is 65-percent flame resistant rayon, 25-percent para-aramid and 10-percent nylon.
- c. The fabric of the IHWCU is 57-percent nylon and 43-percent cotton. Material is no melt, no drop.

#### **5-5. Insignia and accouterments**

The following insignia and accouterments are authorized for wear on the combat uniform:

- a. Identification badges.
- b. Combat and special skill badges (see para 14-13).
- c. Special skill tabs (see para 14-14).
- d. Brassards.
- e. Branch insignia.
- f. Grade insignia.
- g. Headgear insignia.
- h. Shoulder sleeve insignia (SSI), current organization.
- i. Shoulder sleeve insignia-former wartime service (SSI-FWTS).
- j. Insignia, distinguishing, MICHIGAN tape and nametape.
- k. Full color State of Michigan flag embroidered insignia.

#### **5-6. Badges worn on the combat uniform.**

Foreign badges are not authorized for wear on the combat uniform. Pin-on badges are not authorized in a field or deployed environment. See paragraphs 5-8e, for wear of identification badges, and combat and skill badges on the combat uniform.

#### **5-7. General guidelines**

- a. Service members are authorized to wear the approved undershirt, rigger belt, and combat boots with the ACU.
- b. Pockets of the combat uniform will be worn closed at all times.
- c. Service members may wear gloves with the combat uniform without the cold-weather outer garments (for example, Extended Cold Weather Clothing System (ECWCS) cold weather jacket or field jacket).
- d. When the cold-weather coat or other authorized cold weather outer garments are worn, service members may wear the olive-green scarf and gloves, but are not required to do so. Service members may wear the hood of the cold-weather coat and wet-weather jacket at their option. However, when the hood is not worn, service members will tuck the hood into the coat or jacket with the zipper closed.
- e. Service members may wear the ECWCS jackets and trousers as outer garments, to include the layer III fleece jacket, when authorized by the commander.
- f. Service members are authorized to wear elbow or knee pads with the combat uniform.
- g. The silk weight (cold-weather) moisture-wicking undershirts are not authorized to be worn under the combat uniform coat in place of the approved undershirt. The silk weight (cold-weather) undershirts will be worn as undergarments only.
- h. Female personnel may carry purses/handbags with these uniforms only while in a garrison environment. Such bags must comply with standards set forth in AR 670-1, paragraph 3-7f.
- i. Commanders may authorize use of a camouflage, black, or solid color (in a similar color to match the shade of the uniform) personal hydration system only in the following situations: in a field environment, in high-heat areas, or on work details. Service members will not wear hydration systems in a garrison environment unless the commander has authorized it for one of the situations described above. Service members will not let the drinking tube hang from their mouths when the device is not in use.
- j. Service members are authorized to store headgear when it is not worn. Service members may store headgear in the cargo pockets. When stored, the headgear must be folded neatly and not present a bulky appearance.
- k. The following insignias are not authorized to be worn on the combat uniform: blood types, combat lifesavers, allergies, no known drug allergies, no known allergies, and penicillin.
- l. The standard combat uniform coat and trousers, both issued and available at military clothing stores, are pre-treated with permethrin, which provides protection from disease-carrying insects. Female service members who are pregnant, trying to become pregnant, or nursing, may obtain authorization to wear non-permethrin treated combat uniforms.

m. The following care instructions must be followed when caring for the combat uniform to maximize the service life and maintain optimum performance. Service members will—

(1) Not starch the combat uniform under any circumstances. Using starch, sizing, and any process that involves dry cleaning or a steam press will adversely affect the treatments and durability of the uniform and is not authorized.

(2) Wash the combat uniform in cold water and mild detergent containing no optical brighteners or bleach.

(3) Tumble dry the combat uniform at low heat (not to exceed 130 degrees Fahrenheit). Remove immediately from the dryer and fold flat or place on a rustproof hanger to ensure heat from the dryer does not set wrinkles. To drip dry, remove from the washer and place on a rustproof hanger. Do not wring or twist.

(4) Service members may roll press uniforms, as necessary.

n. The ACU–Female (ACU–F) is an authorized alternate ACU designed in a wider range of sizes. If worn, it must have the same general appearance and fit as prescribed for the ACU.

o. The Army combat shirt is designed to provide flame protection for individual service members, while maximizing breathability, moisture management, and comfort when worn as a system including interceptor body armor and FR combat uniform trousers or aircrew combat uniform trousers. It will be worn tucked into the trousers. It is designed for wear next to the skin, without a t-shirt, in hot weather. This does not preclude wear of female undergarments or undershirts currently approved for wear. This shirt will only be worn in a deployed or field environment, as approved by the commander. The right shoulder sleeve of the shirt is equipped with hook and loop for nametape and grade insignia. The left shoulder sleeve is equipped with hook and loop for the SOM flag embroidered insignia.

#### **5–8. Combat uniform coat**

a. The combat uniform coat is worn hooked/looped and/or buttoned and zipped. The coat has hook-and-loop fasteners for wearing the SOM flag insignia, skills tabs, SSI, SSI-FWTS, rank insignia, MICHIGAN tape, and nametape. The coat has a zippered front closure, tilted chest pockets with hook-and-loop closure (which must be closed at all times), hook-and-loop or button sleeve cuff closure (which must be closed at all times), integrated blouse bellows for increased upper body mobility, and shoulder pockets (which must be closed at all times).

b. Uniforms with a mandarin collar will be normally worn in the down position. Service members are authorized to wear the mandarin collar in the up position when weather conditions dictate the wear, as prescribed by the commander.

c. The coat is normally worn outside the trousers but may also be worn inside the trousers when directed by the commander (that is, when wearing the outer tactical vest, mission oriented protective posture gear, and so forth). The undershirt is worn underneath the coat; it is tucked inside the trousers at all times. The coat will not extend below the top of the cargo pocket on the trousers and will not be higher than the bottom of the opening of the side pocket on the trousers. Uniforms equipped with elbow pouches for internal elbow pad inserts must be closed at all times. Permanent infrared feedback squares affixed to each shoulder for nighttime identification will be covered, unless in a field or deployed environment and prescribed by the commander.

d. Commanders may authorize service members to roll-up the sleeves on the Army Combat Uniform. When service members wear the sleeves of the ACU coat rolled up, company level commanders will determine if the unit will roll sleeves with the camouflage pattern exposed or turned inside out. Personnel will roll sleeves neatly above the elbow but no more than 3 inches above the elbow. Upon approval of the commander and only during field training exercises, the sleeves may be down and cuffed inside the coat one or two times. The ACU coat sleeves may be cuffed inside or outside the ACU coat. Personnel will not exceed two rolls or cuffs of the ACU coat.

e. Service members may sew on the MICHIGAN tape, name tape, rank, and all authorized badges as an option. Hook-and-loop fasteners for MICHIGAN tape and name tape may be left on or removed when sewing on the uniform. If worn, badges must be all sewn on or all pinned on; service members are not authorized to mix sew-on badges with pin-on badges. When personnel sew on badges, the following must also be sewn on the combat uniform coat: name tape, MICHIGAN tape, and grade insignia. If a nametape, MICHIGAN tape or grade insignia is sewn on, then personnel must sew all three of these items on the uniform coat. This requirement does not apply to the patrol cap. If service members choose to sew on MICHIGAN tape, rank or authorized skill badges, it will be at their own expense. Service members may wear pin-on badges with sewn on name tape, MICHIGAN tape, and grade insignia. Service members are not authorized to wear pinned on badges in a field or deployed environment.



### **5–9. Combat uniform trousers**

a. The combat uniform trousers are worn buttoned and with a belt. Service members will wear the trousers tucked into the top of the boots or bloused using the drawstrings at the bottom of the trousers, or commercial blousing devices if the trousers are not tucked into the boots. Personnel will not wrap the trouser leg around the leg tightly enough to present a pegged appearance or insert any items inside the trouser leg to create a round appearance at the bottom of the trouser leg. When bloused, the trousers will not extend below the third eyelet from the top of the boot.

b. Uniforms equipped with knee pouches for internal kneepad inserts must be closed at all times.

### **5–10. Headgear**

a. Patrol cap.

(1) General. The patrol cap is standard headgear worn with the combat uniform in the garrison environment. The patrol cap has a visor, circular top crown, side crown with an outside crown band, and a hook-and-loop pad on the back of the patrol cap.

(2) Wear. Personnel wear the patrol cap straight on the head so that the cap band creates a straight line around the head, parallel to the ground. The patrol cap will fit snugly and comfortably around the largest part of the head without bulging or distortion from the intended shape of the headgear and without excessive gaps. No rolling of, blocking, or alterations to the cap are authorized. The cap is worn so that no hair is visible on the forehead beneath the cap. The nametape will be worn centered on the hook-and-loop pads on the back of the patrol cap. Subdued pin-on or sew-on grade insignia, or branch insignia for chaplains, is worn centered on the front of the headgear left to right, and top to bottom. Service members may sew on the nametape and/or grade insignia as an option. Hook-and-loop fasteners for the nametape may be left on or removed when sewing it on to the patrol cap. If service members choose to sew on the nametape or grade insignia, it will be at their own expense.

b. Fleece cap. Commanders may authorize wear of the approved fleece cap with the combat uniform in field environments when the Army combat helmet is not worn, on work details, or in other environments where wearing the patrol cap is impractical. Personnel wear the fleece cap pulled down snugly on the head. In order to wear the cap properly, the bottom edge (all) of the cap may be folded, but not rolled. Installation commanders will determine temperature, wind chill, and extended duty time warranting wear of the cap in non-field, non-deployed environments.

c. Sun (Boonie) hat. The sun hat is an OCIE item authorized for wear with the combat uniform in field environments when the advanced combat helmet is not worn, on work details, or in other environments where wearing the patrol cap is impractical, as determined by the commander. Personnel wear the sun hat straight on the head so that the web band creates a straight line around the head, parallel to the ground. The sun hat will fit comfortably around the largest part of the head without distortion or excessive gaps. The sun hat is worn so that no hair is visible on the forehead beneath the hat. The drawstring on the sun hat can be worn under the chin, around the back of the head and neck, or tucked inside. The drawstring will not be worn over the top of the sun hat. The sun hat will not be worn rolled, formed, shaped, blocked, or with an upturned brim. Subdued pin-on or sew-on grade insignia, or branch insignia for chaplains, is worn centered on the front of the headgear left to right, and top to bottom.

d. Officers and WOs wear non-subdued grade insignia centered on the beret flash, and chaplains wear their branch insignia. General officers may wear full, medium or miniature-sized stars on the beret. Stars are centered horizontally on the flash point-to-point, and they may be mounted on a bar as an option. Overlapping stars beyond the flash is authorized. Enlisted personnel wear this distinctive unit insignia (DUI) centered on the beret flash, except as follows.

## **Chapter 6**

### **Maternity Work Uniform**

#### **6–1. Classification**

The ACU maternity work uniform is a daily work and utility uniform for pregnant service members.

#### **6–2. Composition**

The maternity work uniform consists of:

a. Coat, maternity. A single-breasted coat style design with a collar, two patch pockets with flaps, a straight-cut bottom, sleeve tabs, and pleated side-body panels with take-up tabs.

- b. Trousers, maternity. The trousers have a front stretch panel with an elasticized waistband and side pockets, with flaps on both legs.
- c. Undershirt.
- d. Undergarments.
- e. Socks, tan, green, or black, tan; cushion sole.
- f. Boots, combat.
- g. Headgear.

### **6-3. Accessories**

The following accessories are normally worn with the maternity work uniform:

- a. Beret
- b. Chaplain's apparel (chaplains only).
- c. Gloves, utility.
- d. Handbag.
  - (1) Black, clutch-type, optional purchase.
  - (2) Black, shoulder.
- e. Hat, drill sergeant.
- f. MP accessories.
- g. Neck gaiter, optional purchase or OCIE.
- h. Scarf, utility.
- i. Fleece cap.
- j. OCIE, as determined by the commander in accordance with CTA 50-900 or CTA 8-100 (medical personnel).
- k. Personal hydration systems.
  - l. Coat, cold weather (field jacket). The coat is lined, hip length with a bi-swing back, convertible stand-up collar with concealed hood and a slide-fastener front closure, with two breast and two lower pockets.
  - m. OCIE, as determined by the commander in accordance with CTA 50-900 or CTA 8-100 (medical personnel).

### **6-4. Materials**

Fabric is 100 percent ripstop cotton (old fabric blend), or a 50/50 nylon and cotton ripstop poplin (new fabric blend).

### **6-5. Insignia and accouterments**

The following insignia and accouterments are authorized for wear on the maternity work uniform:

- a. Identification badges
- b. Combat and special skill badges
- c. Special skill tabs. Any federally awarded skill tabs and defense force approved skill tabs. Maximum of three, federal take precedent from top. Use of CERT, Amateur Radio and MEMS Academy tabs have been discontinued.
- d. Brassards.
- e. Branch insignia.
- f. Grade insignia.
- g. Headgear insignia.
- h. Shoulder sleeve insignia (SSI), current organization.
- i. Shoulder sleeve insignia-former wartime service (SSI-FWTS).
- j. Shoulder sleeve insignia-defense force military operations in hazardous/hostile conditions (SSI-DMOHC).
- k. Insignia, distinguishing, MICHIGAN tape and nametape.
- l. Full color SOM flag embroidered insignia.

### **6-6. Badges worn on the maternity work uniform**

Foreign badges are not authorized for wear on the ACU maternity work uniform. Pin-on badges are not authorized in a field or deployed environment.

### **6-7. General guidelines**

- a. Service members are authorized to wear the approved undershirt and combat boots with maternity work uniform.
- b. Pockets will be worn closed at all times.

- c. The standard headgear for this uniform is the patrol cap.
- d. Service members may wear gloves with the maternity work uniform without the cold weather outer garments (for example, ECWCS cold weather jacket or field jacket).
- e. When cold-weather outer garments are worn, service members may wear gloves but are not required to do so.
- f. Service members may wear the ECWCS jackets and trousers as outer garments, to include the layer III fleece jacket, when authorized by the commander.
- g. This uniform is designed to fit loosely; alterations to make the uniform fit tightly are not authorized. A tight fit reduces the airflow needed for ventilation and cooling. The coat is worn outside the trousers. Service members will not wear a belt with this uniform. Service members will wear the trousers tucked into the top of the boots or bloused using the drawstrings at the bottom of the trousers, or commercial blousing devices if the trousers are not tucked into the boots. Personnel will not wrap the trouser legs around the leg tightly enough to present a pegged appearance or insert any items inside the trouser leg to create a round appearance at the bottom of the trouser leg. When bloused, the trousers will not extend below the third eyelet from the top of the boot.
- h. When service members wear the sleeves of the ACU coat rolled up, company-level commanders will determine if the unit will roll sleeves with the camouflage pattern exposed or turned inside out. Personnel will roll sleeves neatly above the elbow but no more than 3 inches above the elbow. Upon approval of the commander and only during field training exercises, the sleeves may be down and cuffed inside the coat one or two times. The ACU coat sleeves may be cuffed inside or outside the ACU coat. Personnel will not exceed two rolls or cuffs of the ACU coat.
- i. The silk weight (cold-weather) moisture-wicking undershirts are not authorized for wear under the maternity work uniform coat in place of the approved undershirts. The silk weight (cold-weather) undershirts will be worn as undergarments only.
- j. Female personnel may carry purses and/or handbags with these uniforms only while in a garrison environment. Such bags must comply with standards set forth in this publication.
- k. Commanders may authorize using a camouflage, black, or solid color (in a similar color to match the shade of the uniform) personal hydration system only in the following situations: in a field environment, in high-heat areas, or on work details. Service members will not wear hydration systems in a garrison environment unless the commander has authorized it for one of the situations described above. Service members will not let the drinking tube hang from their mouths when the device is not in use.
- l. Service members are authorized to store headgear when it is not worn. Service members may store headgear in the cargo pockets. When stored, the headgear must be folded neatly and not present a bulky appearance.
- m. The following insignia are not authorized to be worn on the maternity work uniform: blood types, combat lifesavers, medic, allergies, Arabic name tapes, no known drug allergies, no known allergies, penicillin, and so forth.
- n. Service members may sew on the MICHIGAN tape, name tape, rank, and all authorized badges as an option. Hook-and-loop fasteners for MICHIGAN tape and name tape may be left on or removed when sewing on the uniform. If worn, badges must be all sewn on or all pinned on; service members are not authorized to mix sew-on badges with pin-on badges. When personnel sew on badges, the following must also be sewn on the maternity work uniform coat: name tape, MICHIGAN tape, and grade insignia. If a nametape, MICHIGAN tape or grade insignia is sewn on, then personnel must sew all three of these items on the uniform coat. This requirement does not apply to the patrol cap. If service members choose to sew on MICHIGAN tape, name tape, rank or authorized skill badges, it will be at their own expense. Service members may wear pin-on badges with sewn on name tape, MICHIGAN tape, and grade insignia. Service members are not authorized to wear pinned on badges in a field or deployed environment.
- o. Footgear other than combat boots may be prescribed as needed. Footgear will be conservative, in good taste, and meet the needs of the individual's profile.
- p. Care instructions are the same as the combat uniform.
- q. Service members will not starch the maternity work uniform under any circumstances. Using starch, sizing, or any process that involves dry cleaning or a steam press will adversely affect the treatment and durability of the uniform, and it is not authorized.

## **Chapter 7**

### **Garrison Culinary Uniform-Male**

#### **7-1. Classification**

The male garrison culinary uniform is one of the daily work uniforms for authorized male enlisted service members who hold the services support specialist MOS (99Q), when prescribed by CTA 50-900 and by the commander. The male Senior Culinary Management NCO uniform is described in paragraph 7-2b.

#### **7-2. Composition**

- a. The male garrison culinary uniform consists of the following:
  - (1) Smock and trousers.
    - (a) Garrison culinary smock. The garrison culinary smock is white, long-sleeved with French cuffs, and has a double-breasted reversible eight-button closure, mandarin-style collar, thermometer pocket on left sleeve, and a straight-cut bottom.
    - (b) Trousers, unisex, garrison culinary, black. The trousers are black with straight legs, partially elasticized waist with belt loops, two front slash pockets, and a front zipper closure.
  - (2) Undershirt, white.
  - (3) Undergarments.
  - (4) Footwear.
  - (5) Beret.
- b. The male culinary management NCO and dining facility manager uniform is worn with the service uniform shirt in place of the smock.

#### **7-3. Accessories**

The following accessories are normally worn with the male garrison culinary uniform:

- a. Belt, black, web waist, brass tip.
- b. Buckle, belt, brass.
- c. Coat, all-weather, black.
- d. Footwear.
  - (1) Boots, safety, leather, combat.
  - (2) Shoes, oxford, black.
- e. Gloves.
  - (1) Black, utility.
  - (2) Black, leather, unisex, dress (worn only with the black all-weather coat)-
- f. OCIE, as determined by the commander in accordance with CTA 50-900.
- g. Scarf, dress, black (worn only with the black all-weather coat).
- h. Socks.
  - (1) Tan, green, or black; cushion sole (worn only with boots).
  - (2) Black, dress (worn only with shoes).
- i. Sweater.
  - (1) Cardigan, black, unisex (worn only with the culinary management NCO and dining facility manager uniform).
  - (2) Pullover, black, unisex (worn only with the culinary management NCO and dining facility manager uniform)-
- j. Windbreaker, black (worn only with the culinary management NCO and dining facility manager uniform).

#### **7-4. Materials**

The fabrics are white polyester and cotton, and black polyester and cotton.

#### **7-5. Insignia and accouterments**

The following insignia are authorized for wear on the male garrison culinary uniform:

#### **7-6. General guidelines**

- a. The garrison culinary smock is worn outside of the black trousers. The smock has a reversible double-breasted front that will be fastened right over left unless the smock becomes soiled during the duty day at which time it may be fastened left over right to maintain a neat appearance. The commander may authorize exceptions to the prescribed wear of the smock for health and safety reasons.

b. The black web belt with brass tip and brass buckle is worn with this uniform. The food handler's apron and food handler's caps are worn only while in the dining facility and within the immediate vicinity of the dining facility. No insignia is worn on the food handler's cap.

c. When the black all-weather coat or other authorized cold weather outer garments are worn, personnel may wear the dress scarf and dress gloves, but they are not required to do so. Personnel may wear the optional purchase, black wind- breaker (with the Senior Culinary Management NCO uniform only), except in formation. Black oxford shoes, combat boots, or safety boots are worn with the garrison culinary uniform, unless CTA 50-900 authorizes other footwear. Service members will not blouse the trousers when wearing boots.

d. The Senior Culinary Management NCO wears the service uniform shirt, black trousers, black oxford shoes, and the beret, when authorized by the commander. Senior Culinary Management NCOs may wear the black unisex cardigan buttoned or unbuttoned while indoors; when outdoors, personnel must button all five buttons. The black web belt with brass tip and brass buckle is worn with this uniform.

e. The garrison culinary and Senior Culinary Management NCO uniforms are organizationally issued utility uniforms (except for the service uniform shirt). However, service members retain these uniforms for as long as they are assigned to culinary duties.

## **Chapter 8**

### **Garrison Culinary and Maternity Uniform-Female**

#### **8-1. Classification**

The female garrison culinary Uniform Slacks and Tunic are one of the daily work uniforms for authorized female enlisted service members who hold the services support specialist MOS (99Q), when prescribed by CTA 50-900 and by the commander. The female Senior Culinary Management NCO uniform is described in paragraph 8-2b.

#### **8-2. Composition**

a. The female garrison culinary uniform consists of:

(1) Dress.

(a) Dress, women's. The dress will be of an approved specification or pattern. It is knee-length with short sleeves and has a front button closure system, wing-tip collars, and a belt.

(b) Dress, maternity, white. The dress is any plain, white, unadorned commercial design, in an easy care, soil-release material, with wing collars suitable for placement of rank and branch insignia, as prescribed. Fabric content must comply with NFPA standards. Any closure method is acceptable, but it may not cause safety hazards or degradation of appearance.

(2) Slacks and tunic.

(a) Uniform, women's, tunic and pants, the uniform will be of an approved specification or pattern. The tunic is an over-the-hip style with winged collars, short sleeves, and side pockets; the pants are straight-legged.

(b) Pantsuit, women's, cotton/polyester, white.

(c) Slacks and tunic, maternity, white. The slacks and tunic may be any plain, white, unadorned commercial design. The fabric is an easy-care and soil-release material, with wing collars suitable for placement of rank and branch insignia, as prescribed. Fabric content must comply with NFPA standards. Any closure method is acceptable, but it may not cause safety hazards or degradation of appearance.

(3) Smock and Trousers.

(a) Garrison Culinary Smock. The garrison culinary smock is white, long sleeved with French cuffs, has a double-breasted reversible eight-button closure, mandarin-style collar, thermometer pocket on left sleeve, and a straight-cut bottom.

(b) Trousers, unisex, garrison culinary, black. The trousers are black with straight-legs, partially elasticized waist with belt loops, have two front slash pockets, and a front zipper closure.

Note. Not all components listed in paragraphs are worn together. Either the dress, the slacks with tunic, the pantsuit, or the smock and trousers is worn.

(4) Undershirt, white.

(5) Undergarments.

(5) Headgear, beret.

(6) Footwear.

b. The female Senior Culinary Management NCO uniform consists of (in addition to items listed in paragraphs a(3) through (5)):

(1) Blouse, women's, food service, white, commercial short-sleeved blouse with a front button closure (local procurement according to CTA 50-900).

(2) Skirt, women's food service, black (local procurement according to CTA 50-900).

(3) Slacks, women's, food service, black (local procurement according to CTA 50-900).

(4) Trousers and service uniform shirt.

Note. Not all components listed in paragraphs b are worn together. Either the women's food service blouse is worn with either the women's food service skirt or the women's food service slacks, or the unisex trousers are worn with the female service uniform shirt.

### **8-3. Accessories**

The following accessories are normally worn with the female garrison culinary uniform:

a. Belt, black web, with brass tip and buckle.

b. Coat, black, all weather.

c. Windbreaker, black (worn only with Senior Culinary Management NCO uniform).

d. Gloves

(1) Black, utility.

(2) Black, leather, unisex, dress (worn only with black all-weather coat).

e. Scarves, dress, black (with all-weather coat only).

f. Footwear

(1) Boots, combat.

(2) Shoes, oxford, black.

g. Socks

(1) Tan, green, or black, tan; cushion sole (worn only with boots).

(2) Black, dress (worn with shoes only).

h. Stockings, sheer.

i. Sweater

(1) Cardigan, black, unisex (worn only with the Senior Culinary Management NCO uniform).

(2) Pullover, black, unisex (worn only with the Senior Culinary Management NCO uniform).

j. Handbags

(1) Black, clutch-type, optional purchase.

(2) Black, shoulder.

k. OCIE as determined by the commander in accordance with CTA 50-900.

### **8-4. Materials**

The fabrics are white polyester and cotton, and black polyester and cotton.

### **8-5. Insignia and accouterments**

The following insignia are authorized for wear on the female garrison culinary uniform:

a. Grade insignia, non-subdued.

b. Headgear insignia.

c. Nameplate.

### **8-6. General guidelines**

a. The garrison culinary smock is worn outside of the black trousers. The smock has a reversible double-breasted front that will be fastened right over left unless the smock becomes soiled during the duty day at which time it may be fastened left over right to maintain a neat appearance. The commander may authorize exceptions to the prescribed wear of the smock for health and safety reasons.

b. The black web belt with brass tip and brass buckle is worn with this uniform. The food handler's apron and food handler's caps are worn only while in the dining facility and within the immediate vicinity of the dining facility. No insignia is worn on the food handler's cap.

c. When the black all-weather coat or other authorized cold-weather outer garments are worn, personnel may wear the dress scarf and dress gloves, but they are not required to do so. Personnel may wear the optional purchase, black wind-breaker (with the Senior Culinary Management NCO uniform only) (see para 18-32), except in formation. Black oxford shoes, combat boots, or safety boots are worn with the garrison culinary uniforms, unless CTA 50-900 authorizes other footwear. Service members will not blouse the trousers when wearing boots. Service

members will wear either black socks or sheer stockings with the black oxfords, with the pantsuit, or with the tunic with slacks. Sheer stockings are worn with the garrison culinary uniform dresses. The slacks are not bloused when wearing boots.

d. The Senior Culinary Management NCO wears the white blouse or service uniform shirt, black slacks or skirt, black oxford shoes, and the beret, when authorized by the commander. Senior Culinary Management NCOs may wear the black unisex cardigan buttoned or unbuttoned while indoors; when outdoors, personnel, except for pregnant service members, must button all five buttons. The black web belt with brass tip and brass buckle is worn with this uniform.

e. The garrison culinary and Senior Culinary Management NCO uniforms are organizationally issued utility uniforms (except for the service uniform shirt). However, service members retain these uniforms for as long as they are assigned to culinary duties.

f. Issuing the garrison culinary maternity uniform to female personnel has no bearing on issuing the maternity service uniform or the maternity work uniform.

## **Chapter 9**

### **Army Service Uniform (ASU/AGSU)**

#### **9-1. General guidelines (ASU)**

a. The Army Service Uniform (Class A and Class B uniform), as adopted by the defense force, is intended for wear during most on-duty, non-field or utility occasions, and off-duty social purposes. While both the Class A and B uniforms are authorized for year-round wear, the appropriate uniform is worn based on weather conditions, duties, and the formality of the occasion. When a specific uniform is not prescribed for formations or other occasions when uniformity is required, service members may wear the Class A or any of the variations of the Class B uniform with the accessories authorized for these uniforms. Commanders will not require the wear of optional items such as windbreakers or sweaters. Uniform design and general fitting instructions are provided DA PAM 670-1.



**Figure 9-1.** Class A blue Army Service Uniform (ASU) officer, male and female



**Figure 9-3.** **Figure 9-4.**  
**Class A blue ASU enlisted (E5 and above), female and male**



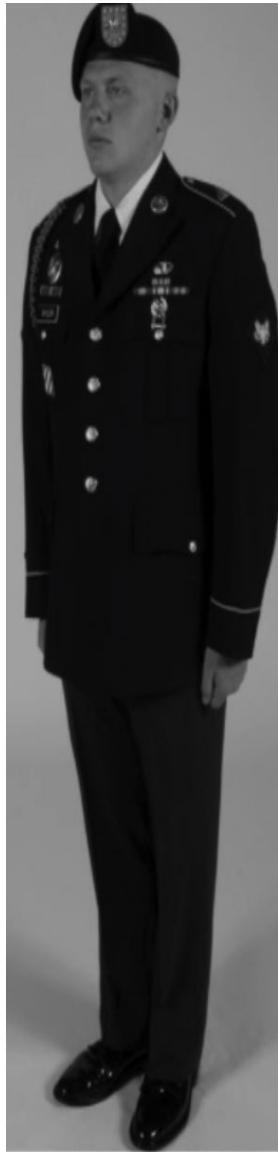

Figure 9-5. Figure 9-6.  
Class B enlisted (E4 and below) blue ASU, male and female



Figure 9-7. Figure 9-8.  
Class B blue ASU officer, male



Figure 9-9.  
Class B service blue officer, female



Figure 9-10.  
Class A service blue officer, female



Figure 9-11.  
Class A blue ASU NCO (E4 and below) variations

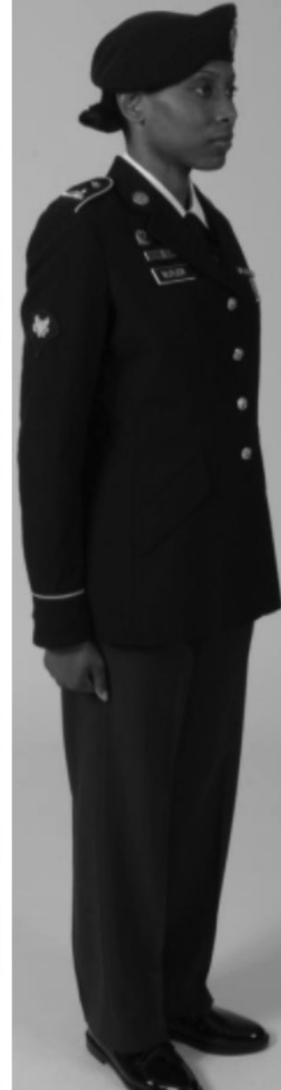

Figure 9-12.



Male

Female

Figure 9-13.

Class B blue ASU enlisted (E4 and below)

### 9-2. Defense force Army Green Service Uniform (AGSU) Implementation Strategy

Principle Official Guidance Memorandum (POG) Army Green Service Uniform (AGSU) Approved Announcement and Wear Guidance dated, 16 September 2019. The AGSU has an optional dress variation for personnel when worn after retreat.

### 9-3. General guidelines (AGSU)

a. The AGSUs are intended for wear during most duty, non-field, or utility occasions and for travel and off-duty purposes. While both the Class A and B AGSUs are authorized for year-round wear, the appropriate uniform is worn based on weather conditions, duties, and the formality of the occasion. When a specific service uniform is not prescribed for formations or other occasions when uniformity in appearance is not required, service members may wear the Class A AGSU or any of the variations of the Class B AGSU with the accessories authorized for these

uniforms.

b. Service members will not wear those awards and decorations on the heritage that they cannot wear properly because of size or configuration. Commanders will not require the wear of optional items, such as windbreakers or sweaters, unless such items are provided to the service members without cost.

c. Individuals who purchase uniforms or uniform items from commercial sources are responsible for ensuring that the items conform to military specifications or are manufactured in accordance with the policies prescribed by the uniform quality control program (see AR 670-1 for details). Only those alterations authorized by AR 700-84 and TM 10-227 are authorized. Uniform design and general fitting instructions are provided DA PAM 670-1.

#### **“New” Army Green Service Uniform AGSU**



**Figure 9-14. Class A AGSU Male/Female NCO (E6 and above)**

#### **9-4. Defense Force uniform adaptations**

a. Consistent with US Army SOPs, the following adaptations are made to the Army Service Uniform. These adaptations are required for defense force personnel to be in compliance with defense force and US Army SOPs.

(1) Buttons: On the Army Service Uniform, defense force personnel must wear the defense force or State of Michigan dress buttons, in lieu of any style of US Army Buttons.



**Figure 9-15. Defense Force/State of Michigan buttons**

(2) Collar Device: defense force enlisted personnel shall wear the MICHIGAN Collar Device and officers shall wear the MICHIGAN Collar Device in lieu of the US Army Service Collar Devices.



**Defense Force officer Collar Device**



**Defense Force Enlisted Collar Device**

**Figure 9-16.**

(3) Nameplate: All defense force personnel shall wear the red defense force nameplate. See Section 7-14 for description.



**Defense Force nameplate**  
**Figure 9-17**

(4) Service Cap Insignia: Defense force personnel shall wear the MI Service Cap Insignia in lieu of the US Army Service Cap Insignia. The Insignia uses a modified US Army Cap Insignia to include a Michigan State Seal. The DCS, S4 shall maintain a list of vendors for these devices.



**Enlisted**



**Warrant Officer**  
**Figure 9-18. Cap Devices**



**Officer**

(5) Distinctive Unit Insignia: All defense force personnel are authorized to wear the defense force Distinctive Unit Insignia (DUI). This insignia shall be worn in compliance with DA PAM 670-1.



**Figure 9-19. Defense Force DUI**

## Chapter 10 Uniform Accessories

### 10-1. General

This chapter lists, in alphabetical order, most uniform accessories referenced in the individual uniform chapters.

### 10-2. Bags, backpacks, handbags, and purses

a. Wear policy for bags, backpacks, handbags, and purses not addressed in this paragraph can be found in AR 670-1.

b. Service members may carry authorized bags by hand, on one shoulder using a shoulder strap, or over both shoulders using both shoulder straps. Service members may not wear a shoulder bag in such a manner that the strap is draped diagonally across the body with the bag resting on the hip opposite the shoulder holding the strap. The bag must be black or match one of the colors of the authorized camouflage patterns when wearing the ACU and Class B uniforms.

c. Handbag, clutch-type, leather, polyurethane, or vinyl.

(1) Type. The handbag is an optional purchase item.

(2) Description. The handbag is made of leather, polyurethane, or vinyl in a commercial design with a zipper, snap, or envelope-type closure.

(3) How worn. Female service members may carry the clutch-type handbag with the female ASU, AGSU, and dress variations and with the utility uniforms while in a garrison (nonfield) environment. The leather version of this handbag is authorized for use with the female ASU, AGSU, and dress variations during and after duty hours. The black leather handbag is worn with the ASU. The brown leather handbag is worn with the AGSU.

d. Handbag, fabric or leather, dress.

(1) Type. The handbag is an optional purchase item.

(2) Description. The handbag is untrimmed, in leather or fabric, of a commercial design, envelope or clutch-type, with or without a chain or strap.

(3) How worn.

(a) Female service members may carry the leather handbag with the female ASU, AGSU, and dress variations during and after duty hours. The black leather handbag is worn with the ASU. The brown leather handbag is worn with the AGSU.

(b) Female service members may carry the fabric handbag with the ASU, AGSU, and dress variations after duty hours.

e. Handbag, shoulder.

(1) Type. The handbag is an optional purchase item.

(2) Description. The handbag is a commercial design in polyurethane or leather with a shoulder strap attached.

(3) How worn. Female service members may carry this handbag with the female ASU, AGSU, and dress variations and with utility uniforms while in a garrison (nonfield) environment. Female service members may carry the bag in the hand or wear it over one shoulder. Service members may not wear the shoulder bag in such a manner that the strap is draped diagonally across the body with the purse resting on the hip opposite the shoulder holding the strap.

### 10-3. Belts and buckles

a. Belt, rigger.

(1) Type. The rigger belt with buckle is a clothing bag issue item.

(2) Description. The belt is cotton web or woven elastic two inches wide.

(3) How worn.

(a) The rigger belt is worn with the attached, open-faced buckle. It is worn so that the tipped end passes through the buckle to the wearer's left; the end will not extend more than two inches beyond the edge of the buckle. The belt's end may be neatly trimmed to ensure a proper fit.

(b) All personnel will wear the rigger and open-faced buckle with utility uniforms that have belt loops.

b. Belt, heritage walnut 567, web waist.

(1) Type. The heritage walnut 567 web waist belt is an optional purchase item.

(2) Description. The unisex belt is heritage walnut 567 cotton web with oxidized brass tip.

(3) How worn. The heritage walnut belt is worn only with the open face buckle. The belt is worn so that the

tipped end passes through the buckle to the wearer's left for male service members and to the wearer's right for female service members and will not extend more than 1 inch beyond the first pant loop.

c. Belt, black, web waist, brass tip.

(1) Type. The brass tip belt is an optional purchase.

(2) Description. The belt is black cotton web or black woven elastic, with a brass tip. The men's belt is 1-1/4 inches wide. The women's belt is 1 inch wide.

(3) How worn.

(a) The brass tip belt is worn only with the brass buckle. The belt is worn so that the tipped end passes through the buckle to the wearer's left for males and to the wearer's right for females. The tipped end will extend beyond the end of the buckle so that only the brass tip is visible, and no fabric portion of the belt can be seen beyond the buckle. The plain end (no tip) of the belt may extend beyond the keeper portion of the inside of the buckle, as long as it is not visible when worn.

(b) Male service members wear the 1-1/4-inch brass tip belt and brass buckle with ASU and dress variation. Male service members may wear suspenders of a commercial design with dress variations, provided that they are not visible.

(c) Female service members wear the 1-inch brass tip belt with the ASU when wearing slacks with the tucked-in version of the dress shirt. Female service members are not required to wear a belt when wearing the overblouse with the slacks.

d. Buckle, open face.

(1) Type. The buckle is an optional purchase.

(2) Description. A unisex, antique finish open face buckle is worn with the heritage walnut 567 web waist belt.

e. Buckle, belt, brass.

(1) Type. The buckle is an optional purchase item.

(2) Description. A brass buckle, 1-11/16 inches long and 1-5/8 inches wide for male Soldiers; 1-1/8 inches by 2 inches for female service members (see fig 10-1).

(3) How worn. The buckle is attached to the end of the black web waist belt with the brass tip and is worn with ASU and dress variations

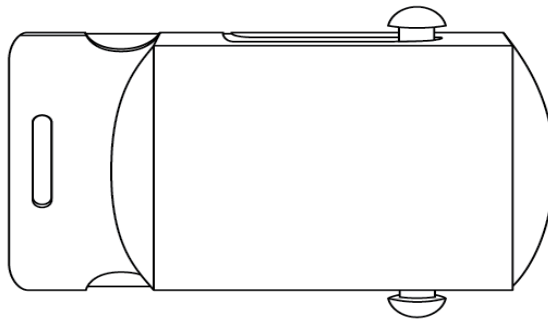

Figure10-1. brass buckle

#### 10-4. Berets

a. Description. The beret is a wool knitted outer shell lined with silesia interlining and with a sweatband. A rayon adjusting ribbon is threaded through the binding. The beret is equipped with a stiffener on the left front and has two eyelets with an eyelet protector on the right side. Except for color, all classes of berets are the same.

b. How worn. The beret is worn so that the headband (edge binding) is straight across the forehead, one inch above the eyebrows. The flash is positioned over the left eye, and the excess materials are draped over to the right ear, extending to at least the top of the ear, and no lower than the middle of the ear. Personnel will cut off the ends of the adjusting ribbon and secure the ribbon knot inside the edge binding at the back of the beret. When worn properly, the beret is formed to the shape of the head; therefore, service members may not wear hairstyles that cause distortion of the intended shape of the beret. The beret is equipped with a stiffener on the left front for attaching organizational flashes and insignia.



(1) The black beret is an optional purchase item but is not the standard headgear for wear with the combat uniform. However, commanders retain the authority to prescribe the black beret for special events such as parades or changes of command/responsibility. The black beret will be affixed with the State Defense Force red flash. The defense force DUI pin will be placed in center of red flash for enlisted personnel; officers will wear bright rank insignia centered in flash.

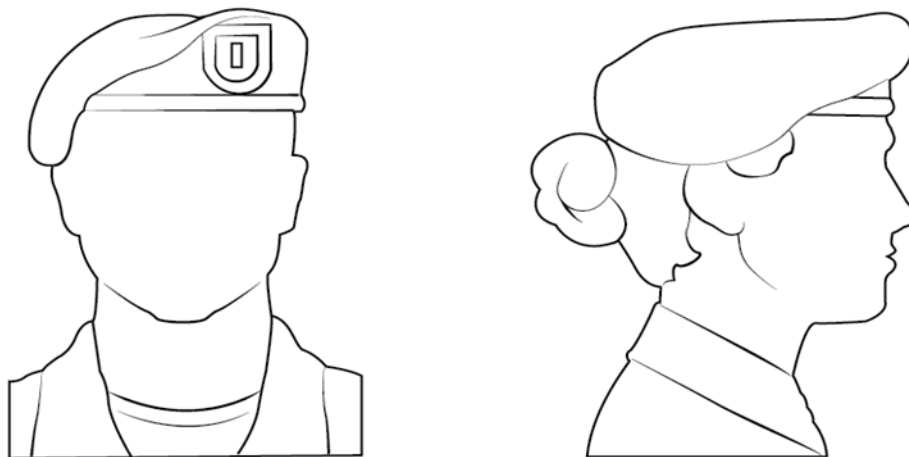

**Figure 10-2. State Defense Force beret flash**



**Figure 10-3. Defense Force black beret**

c. Officers and WOs wear non-subdued grade insignia centered on the beret flash, and chaplains wear their branch insignia. General officers may wear full, medium or miniature-sized stars on the beret. Stars are centered horizontally on the flash point-to-point, and they may be mounted on a bar as an option. Overlapping stars beyond the flash is authorized. Enlisted personnel wear the distinctive unit insignia (DUI) centered on the beret flash.



**Figure 10-4. Wear of the beret, male and female**

## 10-5. Boots

a. Boots, combat, leather. The Army combat boots (hot weather) are clothing bag issue items.

(1) Description. The issue Army combat boots (hot weather) are made of flesh-side out cattlehide leather and nylon duck upper, removable cushioned insert, a closed-loop speed lace system, and drainage eyelets. It is recommended that service members possess two pairs of Army combat boots.

(2) How worn.

(a) The boots are laced diagonally; the color of the bootlaces will match the color of the boot, with the excess lace tucked into the top of the boot under the bloused trousers or slacks or wrapped around the top of the boot. Metal or plastic cleats and side tabs are not authorized for wear. Sewn-in or laced-in zipper or hook-and-loop inserts are not authorized.

(b) Rubber or pure polyether polyurethane soles are the only outsole material that currently meets the need for durability and traction on surfaces in multiple environments and temperature ranges. Other materials (that may be of a lighter weight) may have significant problems in these areas.

b. Optional boots.

(1) As an option, service members may wear commercial boots of a design similar to that of the Army combat boot, as authorized by the commander. The boots must be between 8 to 10 inches in height and made of flesh-side out cattlehide leather, with a plain toe and a soling system matching the color of the upper materials. Rubber and polyether polyurethane are the only outsole materials that are authorized. The soling materials will not exceed two inches in height, when measured from the bottom of the outsole, and will not extend up the back of the heel or boot or over the top of the toe. The exterior of the boot upper will not contain mesh but will be constructed of either all leather or a combination of leather and non-mesh fabric.

(2) The combat leather boot is made of leather with a deep lug tread sole made of vulcanized rubber, a removable cushioned insert, a closed-loop speed lace system, and a leather padded collar. A vulcanized rubber sole is the only outsole material that currently meets the need for durability and traction on surfaces. Other materials that may be of a lighter weight may have significant problems in these areas.

(d) Optional boots are not authorized for wear when the commander issues or prescribes standard organizational footwear for safety or environmental reasons, such as insulated boots or safety shoes. Personnel may wear specialty boots authorized for wear by specific groups of service members, such as the firefighter work boot, only if the commander authorizes such wear. Service members may not wear optional boots in formation when uniformity in appearance is required.

c. Organizational boots. When prescribed and issued by the commander according to CTA 50-900, personnel may wear organizational boots, such as temperate boots or safety boots, with field and utility uniforms.

## 10-6. Buttons

a. Regular defense force for the ASU and AGSU.

(1) Type. The buttons are optional purchase items.

(2) Description. The buttons (see fig 9-15) come in yellow-gold plated and antique finish with the State of Michigan coat of arms superimposed. Buttons are available in 20-ligne, 25-ligne, 30-ligne, and 36-ligne sizes. There are 40 lignes to 1 inch.

(3) How worn. The buttons are worn on the coats and jackets of ASU, AGSU and approved variations.

## 10-7. Chaplain's apparel

a. *Scarves*. Chaplain's scarves are organizational purchase items based on faith and described as:

(1) Christian faith. A scarf of standard Army ecclesiastical pattern, of suitable black material, 9 feet long. On each end, in gold-colored machine embroidery, the scarf is embroidered with the coat of arms of the United States 3 inches high, with the Christian chaplain's insignia, four inches high, spaced one half inch below the coat of arms. The bottom edge of the Christian insignia is six and one half inches from the end of the scarf.

(2) Jewish faith. A scarf of standard Army ecclesiastical pattern, of suitable white or black material, nine feet long. On each end, in gold-colored machine embroidery, the scarf is embroidered with the coat of arms of the United States three inches high, with the Jewish chaplain's insignia, 4 inches high, spaced one half inch below the coat of arms. The bottom edge of the Jewish insignia is six and one half inches from the end of the scarf.

(3) Muslim faith. A scarf of standard Army ecclesiastical pattern, of suitable white or black material, nine feet

long. On each end, in gold-colored machine embroidery, the scarf is embroidered with the coat of arms of the United States three inches high, with the Muslim chaplain's insignia, 4 inches high, spaced 1/2 inch below the coat of arms. The bottom edge of the Muslim insignia is six and one half inches from the end of the scarf.

b. Vestments. Chaplains are authorized to wear the military uniform, vestments, or other appropriate attire prescribed by ecclesiastical law or denominational practice, when conducting religious services.

c. Chaplain and chaplain candidate insignia.

d. How worn. Chaplains may wear the chaplain's scarf or stole with the uniform, vestments, or other appropriate attire when conducting religious services.

#### **10-8. Coat, all weather (male and female)**

a. Heritage green.

(1) Type. The heritage green all-weather coat is an optional purchase item.

(2) Description. The heritage green all-weather coat is made of 65-percent polyester and 35-percent cotton. The coat is a six-button, double-breasted model with a belt, convertible collar that buttons at the neck, gun flap, shoulder loops, adjustable sleeve straps, welt pockets with two inside hanging pockets, and zip-out liner (see fig 10-3). The back of the coat has a yoke and center vent. The coat is one-quarter lined with basic material. The sleeve lining is made of nylon taffeta. There is no wear-out date for the interim version of the double-breasted coat made from 50- percent polyester and 50-percent cotton.

b. Black. The black all-weather coat is an optional purchase item and is authorized for wear with the ASU and culinary and mess uniforms.



**Figure 10-5. Coat, all-weather with officer insignia**

c. How worn. Personnel may wear the all-weather coat with or without the liner. They will wear the coat buttoned, except for the neck closure, which personnel may wear open or closed (unless otherwise prescribed by this SOP). Male and female coats are buttoned and belted from opposite directions. The black scarf is authorized for wear with the all-weather coat. Personnel may wear the coat with the ASU, AGSU, dress variations, and garrison culinary uniforms. The black, all-weather coat is authorized for wear with utility uniforms only in a garrison environment when personnel have not been issued organizational rain gear. When the grade insignia is removed

from the coat, personnel may wear the coat with civilian clothing.

(1) Black all-weather coat. Officers wear non-subdued pin-on grade insignia on the shoulder loops of this coat. NCOs wear shoulder marks on the shoulder loops. Enlisted personnel wear non-subdued grade insignia on the collars.

(2) Heritage green all-weather coat. All ranks wear non-subdued pin-on grade insignia on the shoulder loops of this coat.

#### **10-9. Cover, cap, rain**

a. Type. The cap cover is an optional purchase item.

b. Description. The cover is made of transparent plastic with a visor protector. There is elastic webbing around the peripheral opening of the crown cover and the edge of the visor cover.

c. How worn. Males may wear the cover when wearing the blue service cap. The cover will completely cover the crown and visor.

#### **10-10. Cufflinks and studs**

a. Type. Cufflinks and studs are optional purchase items.

b. Description. Male service members may wear the cuff links and studs with the following uniforms:

(1) The ASU and dress variations. Personnel may wear gold or gold-colored metal studs or cuff links with a round, plain face. The cuff links may be post or link type, 1/2 to 3/4 inch diameter; studs may be 1/4 to 3/8 inch in diameter.

#### **10-11. Fleece Cap**

a. Fleece cap, black.

(1) Type. The fleece cap is an optional purchase item.

(2) Description. The fleece cap is a single ply, bell shape, pull-on style cap of plain, black fleece or microfiber material.

b. Fleece cap, coyote brown.

(1) Type. The fleece cap is an optional purchase item.

(2) Description. The fleece cap is a single ply, bell shape, pull-on style cap of plain, coyote brown fleece or microfiber material.

c. How worn. Personnel wear the fleece cap pulled down snugly on the head with the bottom edge covering the ears, but not covering the eyebrows. The bottom edge (all) of the cap may be folded, but not rolled. The fleece cap is worn with the DPFU/ADPFU or the combat uniform, as prescribed by the commander.

#### **10-12. Garrison cap, Army green**

a. Type. The garrison cap is an optional purchase item.

b. Description. The cap will be made from an approved specification or pattern.

c. How worn. The garrison cap may be worn by all personnel with Class A or B AGSU. The garrison cap is worn with the front vertical crease of the cap centered on the forehead in a straight line with the nose, with the front lower portion of the cap approximately 1 inch above the eyebrows (approximately the width of the first two fingers). The cap is placed on the head in such a manner that the front and rear vertical creases and the top edge of the crown form unbroken lines in silhouette, and the ridge of the cap is parallel to the ground while standing at attention. Personnel will not crush or shape the crown of the cap to form peaks at the top front or top rear of the cap.

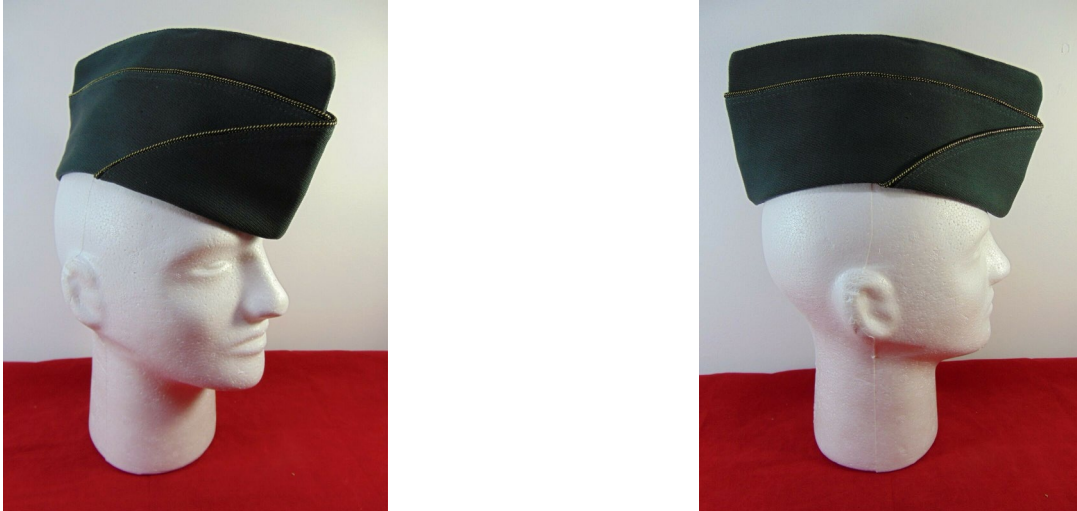

**Figure 10–6. Garrison cap**

### **10–13. Gloves**

#### **a. Gloves, utility.**

(1) Type. The gloves are clothing bag issue items.

(2) Description.

(a) Light duty utility. The gloves are four-finger-and-thumb type design in a slip-on style. This glove may be worn alone or as a shell with inserts. This glove may also be worn in combination with thermal inserts or chemical protection handwear.

(b) Black, with inserts, unisex, leather shell. The gloves are four-finger-and-thumb type design in a slip-on style. An adjustable strap and buckle is provided on the back of the gloves. The inserts are worn inside the black leather shell gloves. There is no wear-out date for the black leather gloves or the green wool inserts, which may be worn until stocks are exhausted or until unserviceable.

(3) How worn. These gloves are authorized for wear with or without cold-weather outer garments (to include the ACU parka). Service members may wear the gloves with utility uniforms without cold-weather outer garments. Personnel may not wear the inserts without the leather/utility shell gloves when worn with utility uniforms and cold-weather outer garments.

(4) Optional gloves. As an option, service members may wear commercial gloves, unless restricted by the commander, as an optional purchase item. Gloves must be four-finger-and-thumb type design in a slip-on style, all black, plain, with no logos or designs, made of black leather, fabric, or other material of appropriate commercial design.

(5) Flame resistant gloves. Service members are authorized to wear flame resistant gloves issued by the Army, including colors or logos that do not comply with paragraph 20–15a(2) or 20–15a(4) (DA PAM 670–1), in garrison or field environments unless otherwise directed by their chain of command. See the Army Combat Readiness Center for a list of currently approved flame-resistant gloves.

#### **b. Gloves, brown, leather, unisex, dress.**

(1) Type. The gloves are optional purchase items.

(2) Description. The gloves are brown leather in an approved specification or pattern or of a similar commercial design.

(3) How worn. The gloves are authorized for wear with the AGSU and when wearing the all-weather coat, windbreaker, Eisenhower jacket, or leather service jacket.

#### **c. Gloves, black, leather, unisex, dress.**

(1) Type. The gloves are optional purchase items.

(2) Description. The gloves are black leather in an approved specification or pattern, or of a similar commercial design.

(3) How worn. The gloves are authorized for wear with the ASU, AGSU and dress variations and when wearing the black, all-weather coat, windbreaker, or capes.

d. Gloves, white dress.

(1) Type. The gloves are optional purchase items.

(2) Description. The gloves are made of cotton, kid, doeskin, silk, or other material of appropriate commercial design.

(3) How worn. The gloves are authorized for year-round wear with the ASU, AGSU and dress variations. When prescribed by the commander, MP may wear white gloves with service uniforms.

#### **10-14. Neck gaiter**

a. Type. The neck gaiter is an optional purchase item.

b. Description. The neck gaiter is a dark brown or tan knitted cylindrical tube of approximately 10 x 15 inches, consisting of 90 percent polypropylene and 10 percent Lycra. The neck gaiter is camouflage compatible. One size fits all service members.

c. How worn. The neck gaiter is authorized for optional wear with the combat uniforms, maternity work uniforms, and other cold-weather uniforms. It may be worn as a neck warmer, hood, balaclava, ear band, or hat in cold, windy, or dusty environments.

#### **10-15. Neckties, male**

a. Necktie, bow, black, dress or mess.

(1) Type. The bow tie is an optional purchase item.

(2) Description. The material is black silk or satin of a commercial design, without stripes or figures. The bow has square ends not more than 2 1/2 inches wide.

(3) How worn. The black bow tie is worn with the Army dress uniform, and the white and blue mess uniform, after retreat.

b. Necktie, bow, white, evening mess.

(1) Type. The white bow tie is an optional purchase item.

(2) Description. The material is plain white silk or satin, or of the same material as the shirt, without stripes or figures, in a conventional, civilian full-dress style, not more than 2 1/2 inches wide.

(3) How worn. The white bow tie is worn with the Army white and blue evening mess uniform.

c. Necktie, four-in-hand, black, service.

(1) Type. The four-in-hand necktie is a clothing bag issue item.

(2) Description. The material is polyester, wool, tropical, or a similar type of woven fabric; a knitted fabric necktie also is authorized. The necktie will be two-fold, four-in-hand, with pointed ends. As an option, a pre-tied, snap on necktie is authorized for wear.

(3) How worn.

(a) Personnel may wear the tie in a Windsor, half-Windsor, or four-in-hand knot. A conservative tie tack or tie clasp is authorized. The necktie is tied so it is no shorter than 2 inches above the top of the belt buckle, and so it does not extend past the bottom of the belt buckle.

(b) The black four-in-hand necktie is worn with the Class A uniform, and with the short- and long-sleeved service uniform shirts. The necktie is required for wear when the long-sleeved shirt is worn without the Class A coat, and when the short- and long-sleeved shirts are worn with the Class A coat. It is optional when the short-sleeved shirt is worn with the Class B uniform, and when either the short- or long-sleeved shirt is worn with the black pullover or cardigan sweater. The necktie is worn with the Army service/dress uniform before retreat or on duty. Personnel may wear the four-in-hand tie with the blue service/dress uniform after retreat, when the dress code is "military informal."

#### **10-16. Overshoes, black**

a. Type. The overshoes are optional purchase items.

b. Description. The material is rubber or synthetic, of a commercial design.

c. How worn. The overshoes are for optional wear with oxford shoes by male personnel during inclement weather, when not in formation. They are worn with service, dress, and mess uniforms.

#### **10-17. Shirts, white**

a. Shirt, white, formal, female mess.

(1) Type. The shirt is an optional purchase item.

(2) Description. There are two types of optional purchase white formal female mess shirt authorized for wear:

(a) Type I: The shirt is a tuck-in style made of polyester and cotton fabric, with a front closure containing seven

removable, dome-shaped, pearl-like buttons. The shirt has three vertical rows of ruffles on each side of the front opening. It has short sleeves and a rounded collar. A quarter moon shaped neck tab is worn with this shirt.

(b) Type II: The shirt is a tuck-in style made of polyester and cotton fabric, with a front closure containing seven removable, dome-shaped, pearl-like buttons. The shirt has short sleeves, a pleated front, and a rounded collar. A quarter moon shaped neck tab is worn with this shirt.

(3) How worn. The shirt is worn with mess and evening mess uniforms.

b. Shirt, white, semi formal, dress, male mess.

(1) Type. The shirt is an optional purchase item.

(2) Description. The shirt is a white, semi formal dress shirt with long sleeves, a soft-bosom, French cuffs, and a standard turndown collar.

(3) How worn. The shirt is worn with the blue and white mess uniforms.

c. Shirt, white, formal, male evening mess.

(1) Type. The shirt is an optional purchase item.

(2) Description. The shirt is a white, formal dress shirt with long sleeves, a stiff-bosom, French cuffs, and a wing collar.

(3) How worn. The shirt is worn with the evening mess uniforms.

## **10–18. Shoes**

a. Shoes, oxford, black, female.

(1) Type. The shoes an optional purchase item.

(2) Description.

(a) The shoes are made from an approved specification or pattern, or from a similar commercial design and are made of leather, poromeric, or patent leather. The shoe is dress tie-oxford style, with at least three eyelets and a closed toe and heel, with the heel no higher than two inches. The shoe is plain, with no design in the shoe material.

(b) As an option, commanders may authorize females to wear an ankle-high boot, similar to a jodhpurs (riding) boot, when wearing slacks. If worn, the boot must be black, plain, without straps or buckles, with a non-contrasting heel and sole, and a heel no higher than two inches. An inconspicuously placed zipper is authorized.

(2) How worn. The oxford shoe is worn with the service, and garrison culinary uniforms.

b. Optional footwear, inclement weather, female.

(1) Type. The footwear is an optional purchase item.

(2) Description. The footwear is a commercially designed, over-the-foot boot in black leather, rubber, or other synthetic material. The boot must be plain and untrimmed, with heels no higher than two inches. The boots may have an inconspicuously placed zipper or snap-type closure and may not exceed 12 inches in height.

(3) How worn. Females may wear these commercial boots with service uniforms while going to or from duty in inclement weather. They also may wear these boots with the dress and mess uniforms in inclement weather, while in transit. Personnel will exchange the boots for standard footgear when indoors.

c. Shoes, oxford, black, male.

(1) Type. The shoes are an optional purchase items.

(2) Description.

(a) The shoes are made from an approved specification or pattern, or from a similar commercial design and are made of leather, poromeric, or patent leather. The shoe is dress tie-oxford style, with at least three eyelets, and a closed toe and heel. The shoe is plain, with no design in the shoe material.

(b) As an option, commanders may authorize males to wear an ankle-high boot, similar to a jodhpurs (riding) or riding boot. If worn, the boot must be black, plain, without straps or buckles, with a non-contrasting heel and sole, and a heel no higher than 2 inches. An inconspicuously placed zipper is authorized.

(3) How worn. The oxford shoes are authorized for wear with service, dress, mess, evening mess, and garrison culinary uniforms.

d. Optional footwear, inclement weather, male.

(1) The footwear is an optional purchase item.

(2) The footwear is a commercially designed over-the-foot boot in black leather, rubber, or other synthetic material. The boot must be plain and untrimmed, with heels no higher than 2 inches. The boots may have an inconspicuously placed zipper or snap-type closure and may not exceed 12 inches in height.

(3) Males may wear these commercial boots with service uniforms while going to or from duty in inclement weather. They also may wear these boots with the dress and mess uniforms in inclement weather, while in transit. Personnel will exchange the boots for standard footgear when indoors.

e. Shoes, pumps, black or white, female.

(1) Type. Black service pumps are a one-time cash allowance item as part of the initial clothing bag allowance. White service pumps are optional purchase items.

(2) Description. The pumps are of a commercial design in fine grain leather, poromeric, or patent leather. Suede pumps are not authorized. The pumps are untrimmed, with a closed toe and heel. The heel must be at least 1/2 inch but no more than three inches. The sole thickness will not exceed 1/2 inch.

(3) How worn.

(a) Black service pumps are authorized for wear by all female personnel to be worn with the service, dress, and mess uniforms. The black service pumps are required for all female personnel.

(b) White service pumps are authorized for wear by all female personnel with the all-white mess uniforms.

f. Shoes, dress, pumps, black or white, fabric.

(1) Type. The shoes are optional purchase items.

(2) Description. The pumps are of a commercial design in black or white fabric. The pumps are untrimmed, with a closed toe and heel. The heel must be at least 1/2 inch but no more than 3 inches. The sole thickness will not exceed 1/2 inch. When a handbag is carried, the shoes and handbag must be made of the same material.

(3) How worn.

(a) Black dress fabric pumps are authorized for wear with the blue and white mess uniforms; with all evening mess uniforms; and with the Army dress uniform after duty hours.

(b) White dress fabric pumps are authorized for wear with the all-white mess uniform.

### **10–19. Socks**

a. Socks, tan, green, or black, cushion sole.

(1) Type. The socks are clothing bag issue items or optional purchase items.

(2) Description. The socks are tan, green, or black, stretch type, calf-length with a cushion sole.

(3) How worn. The cushion sole socks are worn by all personnel when wearing combat or organizationally-issued boots. They can also be worn as a two-sock system with the standard liner sock (also called the black dress sock) for additional foot protection.

b. Socks, black dress; sock, boot liner.

(1) Type. The socks are clothing bag issue items or optional purchase items.

(2) Description. The socks are made from an approved specification or commercial design. They are calf-length, black polyester and nylon.

(3) How worn. Black socks are worn with black oxford shoes.

c. Stockings, sheer.

(1) Type. The stockings are a one-time cash allowance as part of the initial clothing bag allowance.

(2) Description. The stockings are sheer or semi-sheer, without seams, and of tones complementary to the wearer's skin tone and to the uniform. No patterned or pastel stockings are authorized while in uniform.

(3) How worn. The stockings are worn with the service, dress, and mess uniforms. As an option when wearing slacks, females may wear black socks with the black oxford shoe or the optional ankle boots. The socks must be calf-length, plain, black cotton, or cotton and nylon (see para, above).

### **10–20. Suspenders**

a. Type. Suspenders are optional purchase items.

b. Description. They are of commercial design.

c. How worn. Males may wear suspenders with the dress, mess, and evening mess uniforms, as long as the suspenders are not visible when worn.

### **10–21. Sweaters**

a. Cardigan, black, unisex.

(1) Type. The black cardigan is an optional purchase item.

(2) Description. The black cardigan is 50/50 acrylic and wool, in a long-sleeved coat style, with five buttons, and shoulder epaulets (see fig 10–5).





**Figure 10-7. Black unisex cardigan**

(3) How worn.

(a) The black cardigan is authorized for wear by all personnel with the Class B uniform, and by Senior Culinary Management NCOs with the Senior Culinary Management NCO uniform. Personnel may wear the black cardigan indoors or outdoors. When worn indoors, personnel may wear the cardigan buttoned or unbuttoned; when outdoors, personnel, except for pregnant service members, must button all five buttons.

(b) When the black cardigan is worn with the long- or short-sleeved service uniform shirts, personnel have the option of wearing a necktie or neck tab. Personnel may wear the collar of the shirts inside or outside the cardigan. Personnel may cuff the sleeves of the black cardigan, but they may not roll or push up the sleeves.

(c) Officers and enlisted personnel in the rank of corporal or higher will wear shoulder marks on the epaulets of the black cardigan. Personnel will not wear the nameplate, DUI, or RDI on the black cardigan. Personnel may wear the black cardigan without rank insignia when wearing civilian clothes.

b. Pullover, black, unisex.

(1) Type. The black pullover is an optional purchase item.

(2) Description. The black pullover is available in either 100-percent wool or 100-percent acrylic, in a V-neck style, with shoulder, elbow, and chest patches made in a polyester and cotton fabric.



**Figure 10-8. Black pullover**

(3) How worn.

(a) The black pullover is authorized for wear by all personnel with the Class B uniform and by Senior Culinary Management NCOs with the Senior Culinary Management NCO uniform.

(b) When the black pullover is worn with the long- or short-sleeved service uniform shirts, personnel have the option of wearing a necktie or neck tab. Personnel will wear the collar of the shirts outside the black pullover if they do not wear a necktie or neck tab. Personnel may cuff the sleeves of the black pullover, but they may not roll or push up the sleeves.

(c) Officers and enlisted personnel in the rank of corporal or higher will wear shoulder marks on the epaulets of the black pullover. The nameplate is worn centered 1/4 inch above the bottom of the chest patch, and the DUI is worn centered above the nameplate, from left to right and from top to bottom on the chest patch. Service members not authorized a DUI will wear the RDI instead of a DUI. Chaplains will wear their branch insignia in lieu of the DUI or RDI. Recruiters will wear the recruiting badge in lieu of the DUI or RDI. Personnel may adjust the placement of the nameplate and insignia up or down on the patch, to allow for larger sized DUI or RDI, or to adjust to body configuration.

(d) Personnel may wear the black pullover under the black all-weather coat and black windbreaker. When worn under the windbreaker, the black pullover must not be visible below the windbreaker. Personnel may wear the black pullover without insignia when wearing civilian clothes.

## **10-22. Umbrella**

a. Type. The umbrella is an optional purchase item.

b. Description. The umbrella is black, plain, with no logos or designs, and of a commercial design.

c. How worn. Service members may carry and use an umbrella, only during inclement weather, when wearing

the service (Class A and Class B), dress, and mess uniforms. Umbrellas are not authorized in formations or when wearing field or utility uniforms. Commanders may further restrict service members' use of umbrellas, as appropriate.

### **10–23. Undergarments**

a. Brassieres and underpants (female).

(1) Type. Brassieres and underpants are a one-time cash allowance purchase as part of the initial clothing bag allowance.

(2) Description. Brassieres and underpants may be of a commercial design, in white, black, or other neutral colors that are not readily apparent when worn under the uniform. The category of brassieres also includes sports bras.

(3) How worn. Females will wear brassieres and underpants with all uniforms.

b. Camisole (female).

(1) Type. The camisole is an optional purchase item.

(2) Description. The camisole is of a commercial design in white, black, or other neutral colors not readily apparent under the uniform.

(3) How worn.

(a) Females are authorized to wear the camisole with all uniforms. The camisole is not a substitute for the approved undershirt when the approved undershirt is normally part of the uniform (such as the ACU, cold-weather uniform, and so forth).

(b) The camisole is not a substitute for brassieres. Females will ensure that uniforms fit properly when wearing the camisole.

c. Drawers (male).

(1) Type. Drawers are clothing bag issue items or optional purchase items for males.

(2) Description. The drawers are brown, in brief length.

(3) How worn. Males will wear drawers with all uniforms. Either the brief or boxer style drawers are authorized for wear. Males also may wear commercially purchased brief or boxer versions of drawers, in white, brown, tan, sand, or other neutral colors.

d. Slips (female).

(1) Type. Slips are a one-time cash allowance purchase as part of the initial clothing bag allowance.

(2) Description. Slips will be of a commercial design, in white, black, or other neutral colors not readily apparent under the uniform.

(3) How worn. Females will wear slips with the service, dress, and with the garrison culinary dresses.

e. Undershirt, (male and female).

(1) Type. The undershirt is a clothing bag issue item or optional purchase items.

(2) Description. The material is cotton knitted cloth or 50 percent cotton and 50 percent polyester, with quarter-length sleeves and a crew neck, or is of a similar commercial design.

(3) How worn. All personnel will wear the sand or tan 499 undershirt with all utility uniforms, except for and garrison culinary uniforms.

f. Undershirt, white, crew neck (male).

(1) Type. The crew neck undershirt is a clothing bag issue item for males.

(2) Description. The white undershirt is of a commercial design, short-sleeved, in a crew neck style.

(3) How worn.

(a) Males wear the white crew neck undershirt with the service, dress, mess, and garrison culinary uniforms.

(b) Personnel are not authorized to wear the white crew neck undershirt with the ACU, CVC uniforms, or other utility or field uniforms that require wearing the approved undershirt.

g. Undershirt, white, V-neck.

(1) Type. The V-neck undershirt is an optional purchase item for all service members.

(2) Description. The white V-neck undershirt is of a commercial design, short-sleeved, in a V-neck style.

(3) How worn.

(a) Service members may wear the V-neck undershirt with the service, dress, and garrison culinary uniforms. Females may not substitute the V-neck undershirt for brassieres, and they must ensure that uniforms fit properly when wearing the V-neck undershirt. Males may not substitute the V-neck undershirt for the crew neck undershirt.

(b) Personnel are not authorized to wear the white V-neck undershirt with the ACU, CVC uniforms, or other utility or field uniforms that require wearing the approved undershirt.

### 10-24. Windbreaker, black

a. Type. The windbreaker is an optional purchase item.

b. Description. The black windbreaker is made of polyester and wool (65/35), and has a hook-and-loop-in liner. The officer windbreaker has a knit collar, cuffs, and waist. The enlisted windbreaker has a standard collar, knit cuffs, and waist. Female windbreakers have bust darts. Females are authorized to wear the female or male windbreakers (see fig 10-6).

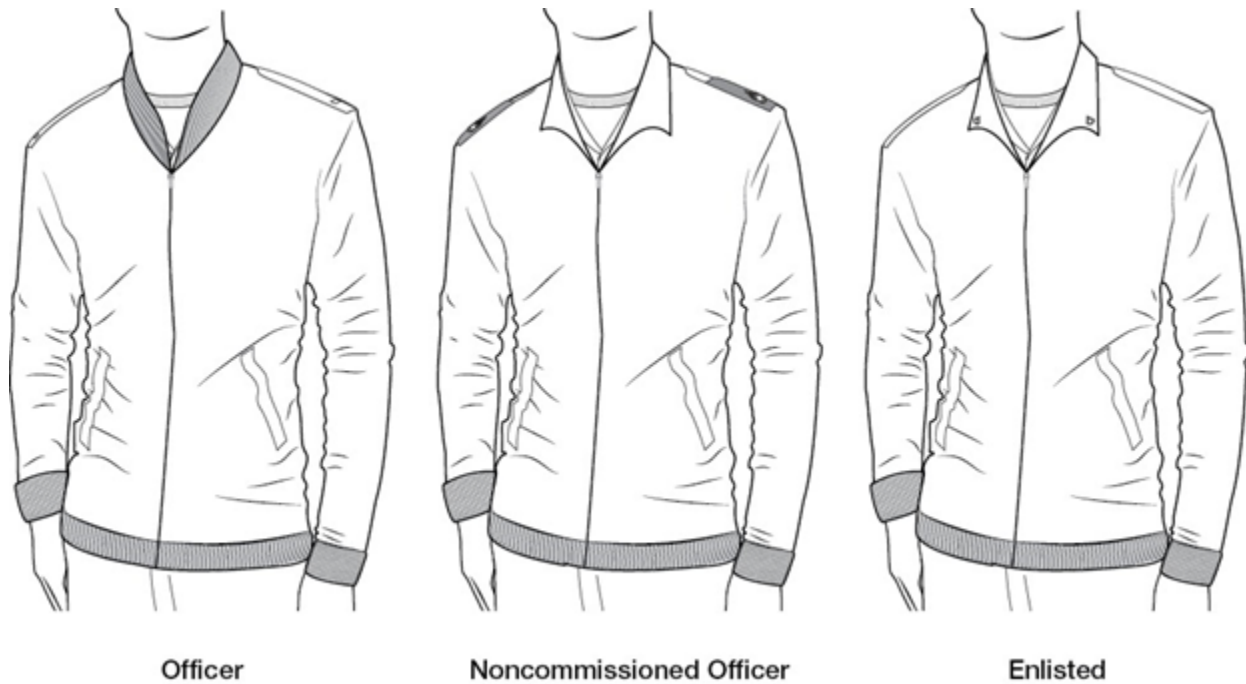

Figure 10-9. Windbreakers

c. How worn. All personnel may wear the windbreaker with the Class B and garrison culinary uniforms. Personnel will not wear the windbreaker in formations unless authorized by the commander. Personnel will wear the windbreaker zipped to at least the second button down from the top of the shirt. Officers wear non-subdued pin-on grade insignia on the shoulder loops of this coat. Noncommissioned officers wear shoulder marks on the shoulder loops. Enlisted personnel wear non-subdued grade insignia on the collars. Personnel may wear the windbreaker without insignia when wearing civilian clothing.

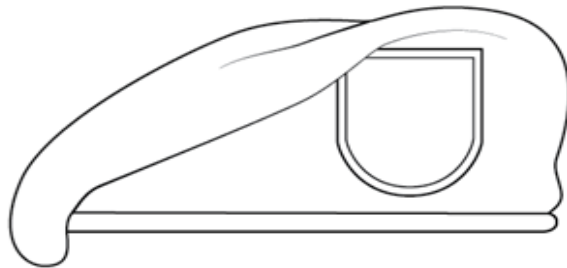
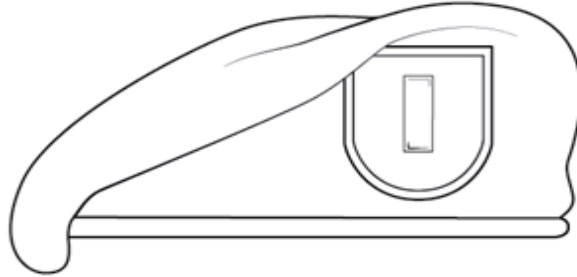

Figure 10-10. Beret with flash

(2) Officers wear non-subdued grade insignia centered on the flash; chaplains wear their branch insignia.



**Figure 10-11. Beret with flash, officer**

(3) Enlisted personnel wear their DUI centered on the flash. Service members assigned to units without a DUI wear the RDI on the flash.

#### **10-25. Shoulder sleeve insignia-current organization**

- a. Authorization. Authorization for shoulder sleeve insignia is found in AR 670-1.
- b. How worn.

(1) All personnel will wear the subdued SSI centered on the hook-and-loop-faced pad already provide on the left sleeve of the utility uniforms. On uniforms with pocket flaps, the SSI is worn centered both horizontally and vertically from the bottom of the pocket flap to the bottom of the pocket. On uniforms without pocket flaps, the SSI is worn centered both horizontally and vertically from the top of the pocket to the bottom of the pocket. If a brassard is worn on a uniform without pocket flaps, the SSI will be worn centered from the bottom of the brassard to the bottom of the pocket. Personnel will not wear the subdued SSI on the garrison culinary uniform. Service members will not sew the SSI on the uniform.



**Figure 10-12. Wearing shoulder sleeve insignia, current organization**

#### **10-26. Shoulder sleeve insignia-former wartime service**

- a. Authorization to wear a SSI indicating FWTS applies only to service members who are/were assigned to U.S. Army units that meet all of the criteria outlined in AR 670-1.
- b. How worn.

(1) Authorized personnel may wear the subdued SSI–FWTS centered on the hook-and- loop-faced pad already provide on the right sleeve of the utility uniform. On uniforms with pocket flaps, the SSI–FWTS is worn centered both horizon- tally and vertically from the bottom of the pocket flap to the bottom of the pocket. On uniforms without pocket flaps, the SSI–FWTS is worn centered both horizontally and vertically from the bottom of the MICHIGAN insignia to the bottom of the pocket. The SSI–FWTS is not authorized for wear on organizational uniforms, except as prescribed in this paragraph.

c. Service members who are authorized to wear more than one SSI–FWTS have the option of choosing which SSI–FWTS they will wear. Service members will not sew the SSI–FWTS on the uniform. Service members may also elect not to wear a SSI–FWTS.

d. Service members who are not authorized to wear the SSI-FWTS will place no insignia, hook-and-loop covers or other accouterment on the right sleeve pocket.

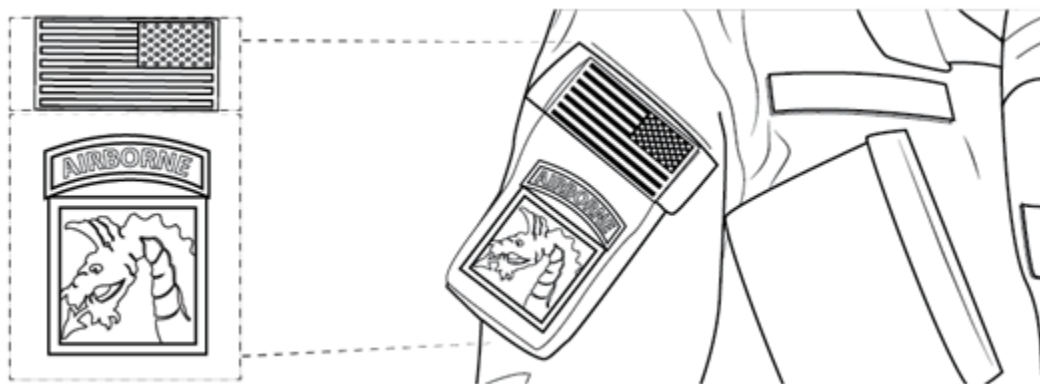

Figure 10–13. Wear of Michigan flag embroidered insignia

e. Description. The colors of the MI flag embroidered insignia (full color). The size is approximately two inches by three inches.

b. How worn.

(1) The MI flag insignia (full color) is worn on the right shoulder pocket flap of utility uniforms. On uniforms with pocket flaps, the flag insignia is placed directly on top of the hook-and-loop-faced-pad already provided on the uniforms shoulder pocket flap. On uniforms without pocket flaps, the flag insignia is worn on the upper most portion of the hook-and-loop-faced pad with the top of the insignia at the top of the pad. Service members will not sew the MI Flag on the uniform.

(2) All personnel will wear the subdued SSI centered on the hook-and-loop faced pad already provided on the left sleeve of the utility uniforms.

## 10–27. Insignia, distinguishing, “MICHIGAN” tape, nametape, and nameplate

a. Insignia, distinguishing, MICHIGAN tape.

(1) Description. For the combat utility uniforms and ECWCS, the insignia is a 5 inches hook-and-loop-faced pad with the inscription “MICHIGAN” in black block letters sewn on a camouflaged pattern tape to match the uniform. The letters are 3/4 inch high and 1/2 inch wide.

(2) How worn. The “MICHIGAN” tape is worn on the wearer's left breast pocket of the combat uniform immediately above the top of the slanted chest pocket flap and parallel to the ground (see fig 19–138). The background of the MICHIGAN insignia is a camouflage pattern that matches the uniform. When personnel sew on badges, the following must also be sewn on the utility uniform coat: nametape, MICHIGAN tape, and grade insignia. This requirement does not apply to the patrol cap. If a service member sews on a MICHIGAN tape, nametape, or grade insignia, then all three items must be sewn on.

Note: Personnel will not wear the MICHIGAN insignia tape on the garrison culinary uniform. Personnel are not authorized to have the words MICHIGAN embroidered directly on the uniform.



**Figure 10–14. Wearing nametape and Michigan distinguishing nametape**

b. Insignia, nametape.

(1) Description. For the combat utility uniforms and applicable ECWCS jackets, the insignia is a five-inch hook-and-loop-faced pad with the individual's last name in black block letters sewn on a camouflaged pattern tape to match the uniform. The name tape is worn above the wearer's right breast pocket above chest pocket flap. The letters are 3/4 inch high and 1/2 inch wide. No punctuation, symbols, or special characters are authorized on the nametape. (Last names consisting of 11 letters or more are constructed using Franklin gothic extra-condensed print (48 point), 1/2 inch high.)

(2) How worn.

(a) Combat Uniform. The nametape is worn on the wearer's right breast pocket of the combat uniform immediately above the top of the slanted chest pocket flap and parallel to the ground. The background of the nametape insignia is a camouflage pattern that matches the uniform. When personnel sew on badges, the following must also be sewn on the utility uniform coat: nametape, MICHIGAN tape, and grade insignia. This requirement does not apply to the patrol cap. If a service member sews on a MICHIGAN tape, nametape, or grade insignia, then all three items must be sewn on.

(b) ECWCS Jacket. For ECWCS jackets with hook-and-loop-faced pads, personnel wear hook-and-loop nametape and MICHIGAN tape insignias on the applicable cold weather garments. For ECWCS jackets without hook-and-loop-faced pads, personnel will wear the name tape on the left sleeve pocket flap. The nametape is a strip of camouflage pattern cloth, 1/2 inch wide and either 3 1/2 inches long or 5 1/4 inches long, depending on the size of the pocket flap, with the individual's last name in 1/4 inch wide black block lettering. The nametape can accommodate up to 14 characters. No other size nametape is authorized to be worn on the parka. The nametape will be centered left to right on the bottom of the pocket flap, 1/4 inch above the bottom of the flap. Personnel are not authorized to wear the nametape in any other location other than the pocket flap, and they are not authorized to embroider the name directly onto the pocket flap.

## **10–28. Defense Force Physical Fitness Uniform (DPFU)**

a. General Guidelines. The defense force DPFU (or Alternate ADPFU) may be worn for the following types of activities:

1. Organized PT activity.
2. PT or Duty Level Qualification Testing (DLQT).
3. Medical examinations.

4. The defense force commander may approve the wearing of the DPFU for personnel involved in athletic competitions where the service member is representing the defense force.

b. Composition. The DPFU consists of the following components:

(1) Sweatshirt / Jacket, black, with defense force, state defense force or SDF centered in the chest in gold, Jackets will have defense force, state defense force or SDF on the left chest in gold.

(2) Sweatpants, black.

(3) Trunks, black, athletic or moisture wicking.

(4) T-shirt, black, with defense force, state defense force or SDF centered in the chest in gold, short sleeve, cotton or moisture wicking.

(5) T-shirt, black, with defense force, state defense force or SDF centered in the chest in gold, long sleeve, cotton or moisture-wicking.

(6) Athletic footwear.

(7) Socks.

c. Accessories The following accessories may be worn with the DPFU.

(1) Gloves.

(2) Fleece cap.

(3) A hooded Sweatshirt / jacket in black, with defense force, state defense force or SDF centered in the chest in gold for the hooded sweatshirt, jacket will have the logo on the left chest and is allowed as an additional to the fleece cap or a substitute to wearing the fleece cap.

(4) PT Reflective belts are required to be worn during nighttime hours only.

d. Materials the DPFU shirts consist of 50/50 cotton or moisture wicking polyester. The DPFU shorts consist of 50/50 or 100% nylon with an antimicrobial finished polyester lining. The DPFU Sweatshirt and pants consist of 50/50 material. Jackets are 100% nylon with mesh lining.

e. Alternate Defense Force Physical Fitness Uniform (ADPFU) Composition

(1) Personnel may wear PT uniform items described above that do not bear the defense force logo or letterings. The items must be of the same material and cut of the DPFU. They may not bear any other logos or emblems, but must be plain black in color.

## **10–29. Unauthorized Uniforms**

a. The following US Army uniforms are *not authorized* for wear by defense force personnel:

- (1) Blue Mess Uniform
- (2) White Mess Uniform
- (3) Air Crew Uniform
- (4) Combat Vehicle Crew Uniform

## **Chapter 11**

### **Cold Weather Uniform**

#### **11–1. General Guidelines**

a. The cold weather uniform (Extended Cold Weather Clothing System (ECWCS)) is available for wear at the wearer's option based on climatic conditions. The local commander may prescribe certain uniforms for wear for uniformity, however, that decision must be tempered by good judgment. Components of the uniform may be intermixed with the utility uniforms. The Gore-Tex® jacket or trousers may also be used as rain gear in temperate weather with any utility uniform to protect the water shedding capability.



## Chapter 12 Insignia and Accouterments

### 12-1 General Guidelines

- a. This SOP specifies the items of an insignia which may be worn on any of the defense force uniforms which differ from AR 670-1.
- b. The insignia worn by defense force personnel designates grade, organization, qualifications and prior military service.
- c. Specialized state insignia shall be worn in the same manner and as federal insignia as prescribed in AR 670-1.

### 12-2. Insignia of Branch

Branch insignia is authorized for service members to wear, based upon assignment to a particular area of service. Personnel will wear the State Defense Force (SDF) branch insignia when branch insignia are required to be worn if there is no similar Army branch assignment within the SDF. The SDF branch insignia, unless otherwise authorized, is the appropriate branch insignia for all defense force personnel.

- a. Service members who are assigned as doctors, dentists, nurses, or other professional medical personnel or specialized career field may wear the appropriate Army branch insignia in lieu of the SDF insignia.
- b. Chaplains, inspectors general, and staff judge advocates, upon certification of branch qualification by their respective section heads, may wear the appropriate Army branch insignia in lieu of the SDF insignia.
- c. General officers will not wear branch insignia.
- d. Refer to paragraph 6-5 for guidance regarding Officer Candidates.
- e. Design.
  - (1) Officers will wear either the SDF insignia or the appropriate insignia described above, based on their assignment.
  - (2) Enlisted persons will wear either the SDF insignia or the appropriate Army insignia described above based on their assignment, mounted on a disc.



Figure 12-1. Branch insignia, enlisted



Figure 12-2. Branch insignia, officer

- f. Manner of wear. The manner of wear will conform to AR 670-1 and DA PAM 670-1.
- g. Chaplain Branch Insignia. Chaplain Candidates shall wear the branch insignia designated for that level of performance. Associate Chaplains, Chaplains and Command Chaplains shall wear the appropriate Chaplain Branch insignia for their faith tradition or endorsement.



**Figure 12-3.**  
**Chaplain Candidate**



**Figure 12-4.**  
**Christian Chaplain**



**Figure 12-5.**  
**Jewish Chaplain**

h. Design. The design of all insignia of grade will conform to that prescribed for wear by the Army in AR 670–1  
i. Manner of wear. The manner of wear for all uniforms will conform to AR 670 –1. Refer to paragraph 6-5 for guidance regarding Officer Candidates.

j. Persons who have been boarded and selected for commissioned rank pending completion of BELT and or Basic Officer Course are Officer Candidates (OC/E6) and as such will wear "Officer Candidate School" insignia ("O.C.S.") or "Warrant Officer Candidate" insignia ("W.O.C.") in lieu of insignia of rank and branch until completion of their required training.

k. Design. The design of all insignia of grade will conform to that prescribed for wear by the Army in AR 670–1.

l. Manner of wear. The manner of wear will conform to AR 670–1.



**Figure 12-6. Officer candidate insignia**



**Figure 12-7. Warrant officer candidate insignia**

## **Chapter 13** **Accessories**

### **13–1. General guidelines**

a. AR 670–1 provides general guidance in the wearing of accessory items. Specific guidance is as follows.

### **13–2. Identification tags**

a. Identification tags (two identical) will be worn around the neck (except when safety considerations apply), when wearing either class C uniform, when engaged in field training, and when traveling in aircraft. These tags are also known as "Dog Tags."

b. Identification tags will contain, at a minimum, the individual's name, serial number, and branch of service (SDF (MI)). Listing of blood type and religious preference is optional, and the accuracy of the listing is the sole responsibility of the individual.

c. Persons who are allergic to certain medications or have other medical conditions are encouraged to wear a medical alert tag on the same chain as the identification tags.

### **13–3. Security identification badges**

Security identification badges will be worn in restricted areas as prescribed by the responsible command.

### **13–4. Nameplate**

a. Description. Nameplates will be in accordance with the following:

(1). Size. 1 x 3 x 1/16 inches (may be longer in the case of a lengthy name.)

- (2). Color. Red (designated color XO3) with white lettering.
  - (3). Material. Laminated plastic.
  - (4). Lettering. The member's last name must be centered and 5/16 inch in height, and "Michigan" centered below the name 3/16 inch in height.
- b. How worn.

(1) Male personnel. The nameplate will be worn on the flap of the right breast pocket, centered between the top of the button and the top of the pocket on the ASU white shirts and the coat of both the ASU and AGSU uniform. See illustrations of individual uniforms. The nameplate will be worn centered on the black patch of the black pullover sweater except when wearing the DUI. When wearing a DUI, the nameplate will be worn ½ inch above the bottom of the black patch with the DUI centered left to right, top to bottom above the nameplate.

(2) Female personnel. On the ASU and AGSU uniforms, the nameplate will be worn between one to two inches above the top button, centered horizontally on the wearer's right side. The nameplate will be worn centered horizontally on the wearer's right side and slightly above the top edge of the top. On the ASU white shirts, maternity tunic, or other duty uniforms, the nameplate is worn in a comparable position. See illustrations of individual uniforms. The nameplate will be centered on the black patch of the black pullover sweater except when wearing the DUI. When wearing a DUI, the nameplate will be worn ½ inch above the bottom of the black patch with the DUI centered left to right, top to bottom above the nameplate. Females may adjust the position of the nameplate and DUI to conform to figure differences.

## **Chapter 14**

### **Wearing of Decorations, Service Medals, Badges, and Unit Awards**

#### **Section I - General Information.**

##### **14-1. General Guidelines**

This chapter covers the decorations, medals, badges, unit awards and appurtenances, U.S., foreign, Michigan, and defense force, which are authorized for wear on the defense force uniform.

##### **14-2. Authorization**

AR 672-5-1 provides the authorization and qualifying criteria for the U.S. decorations, service medals, badges, unit awards and appurtenances worn on Army uniforms and should serve as a guideline for wearing of such in the defense force. All of the above must be verified from a member's DD 214 or NGB 22. Defense Force SOP 600-8-22 (Brigade Awards Program) provides the authorization and qualifying criteria for all defense force awards and decorations authorized for wear on the uniform.

#### **Section II - Precedence of Awards, Decorations, and Medals**

##### **14-3. Order of precedence by category of medals**

The following list indicates the order of precedence by category, when medals from two or more categories are worn at the same time.

- a. Federal military decorations and awards, in accordance with AR 672-5-1 and AR 670-1.
- b. Authorized non-military federal awards.
- c. Authorized foreign awards
- d. State of Michigan awards.
- e. Michigan State Defense Force awards.
- f. Other SDF awards/devices

The following organizations are Congressionally Chartered. The DCS, S1 may authorize, in writing, the wearing of awards or ribbons issued by these agencies. Awards that are approved for wear should reflect significant contributions to public safety or service.

- g. Civil Air Patrol
- h. U.S. Coast Guard Auxiliary

The following organizations provide significant support to the defense force and the State of Michigan. Unless otherwise prohibited, awards issued on behalf of these organizations are approved for wear. The DCS, S1 shall

review awarding documentation and issue appropriate orders authorizing wear.

- i. State Guard Association of the United States (SGAUS).

#### **14-4. Order of precedence within categories of medals**

Refer to AR 672-5-1.

### **Section III - Manner of Wearing Decorations and Medals.**

#### **14-5. Manner of wear of full-size decorations and service medals**

a. Where worn. Full size decorations and service medals may only be worn on the coat of the Class A uniforms when worn for social functions.

b. How worn. All decorations, except the Medal of Honor, will be worn in the order of precedence from the wearer's right to left, in one or more rows, with a 1/8-inch space between rows. Second and subsequent rows will not contain more medals than the row below.

#### **14-6. Manner of wear of service ribbons**

a. Where worn. Ribbons representing decorations and service medals and service and training ribbons will be worn on the coat of the Class A uniform and may optionally be worn on the class B uniform.

b. How worn. Ribbons will be in the order of precedence from the wearer's right to left in one or more rows with a 1/8-inch space between rows. No more than four ribbons will be worn in any one row. The determination of whether three or four ribbons will be worn in each row will be based on the size of the coat and the position of the lapel. The first and second rows will contain the same number of ribbons (three or four) before starting a third row. The third and succeeding rows will contain the same or fewer ribbons that the first two rows. The top row will be centered on the row beneath or aligned to the left - which ever presents the best appearance. Ribbons will be centered 1/8 inch above the left breast pocket in as many rows as necessary.

(1) Male personnel. Ribbons will be worn centered 1/8 inch above the left breast pocket in as many rows as necessary.

(2) Female personnel. Ribbons will be worn centered on the left side with the bottom row positioned parallel to the bottom edge of the nameplate on the coat of the ASU or white shirts. The placement of the ribbons may be adjusted to conform to individual figure differences.

c. Ribbons and medals shall be worn consistent with DA PAM 670-1.

d. 10th award. To display the 10th award, service members may wear a second ribbon, placing it to the wearer's left of the first ribbon. Service members may wear no more than four oak leaf clusters on each ribbon. If the receipt of future awards reduces the number of oak leaf clusters (that is, a silver oak leaf for five awards), service members will remove the second ribbon and place the appropriate number of devices on a single ribbon with any silver clusters being worn to the wearer's right of bronze clusters.

#### **14-7. Manner of wear of miniature decorations and service medals**

Miniature decorations and service medals may be worn on the left lapel of formal civilian attire when wear of defense force uniforms would be inappropriate or not authorized. The wear of combat and special skill badges with miniature medals shall be consistent with DA PAM 670-1.

#### **14-8. Manner of wear of unit award emblems**

a. Description. Unit award emblems with frames will be worn with the laurel leaves of the frame pointing upward. Only one emblem representing the same unit award will be worn. Emblems may be worn as prescribed when wearing full-size medals or service ribbons.

b. Where worn. U.S., foreign, State of Michigan, and defense force unit award emblems will be worn on the ASU/AGSU, and may be worn on the class B uniform.

c. How worn. All unit award emblems with frames will be worn in the order of precedence from the wearer's right to left in rows of not more than three emblems per row and with up to 1/8-inch space between the rows. Emblems with frames will be worn centered and 1/8 inch above the right breast pocket.

d. Foreign unit awards. If a foreign unit award is worn, at least one other award must also be worn. Foreign unit awards are worn after U.S. unit awards by the date of receipt.

e. Defense force unit awards. If a defense force unit award is worn, it will follow the U.S. and foreign unit awards.

f. SGAUS unit awards. If a SGAUS unit award is worn, it will follow the U.S., foreign, and defense force unit

awards.

#### **14-9. Manner of wear of service ribbons**

a. Where worn. Ribbons representing decorations and service medals and service and training ribbons will be worn on the coat of the Class A uniform and may optionally be worn on the Class B uniform.

b. How worn. Ribbons will be in the order of precedence from the wearer's right to left in one or more rows with a 1/8-inch space between rows. No more than four ribbons will be worn in any one row. The determination of whether three or four ribbons will be worn in each row will be based on the size of the coat and the position of the lapel. The first and second rows will contain the same number of ribbons (three or four) before starting a third row. The third and succeeding rows will contain the same or fewer ribbons that the first two rows. The top row will be centered on the row beneath or aligned to the left - whichever presents the best appearance. Ribbons will be centered 1/8 inch above the left breast pocket in as many rows as necessary.

(1) Male personnel. Ribbons will be worn centered 1/8 inch above the left breast pocket in as many rows as necessary.

(2) Female personnel. Ribbons will be worn centered on the left side with the bottom row positioned parallel to the bottom edge of the nameplate on the coat of the ASU/AGSU or ASU white shirts. The placement of the ribbons may be adjusted to conform to individual figure differences.

c. Ribbons and medals shall be worn consistent with DA PAM 670-1.

d. 10th award. To display the 10th award, service members may wear a second ribbon, placing it to the wearer's left of the first ribbon. Service members may wear no more than four oak leaf clusters on each ribbon. If the receipt of future awards reduces the number of oak leaf clusters (that is, a silver oak leaf for five awards), service members will remove the second ribbon and place the appropriate number of devices on a single ribbon with any silver clusters being worn to the wearer's right of bronze clusters.

#### **14-10. Manner of wear of miniature decorations and service medals**

Miniature decorations and service medals may be worn on the left lapel of formal civilian attire when wear of defense force uniforms would be inappropriate or not authorized. The wear of combat and special skill badges with miniature medals shall be consistent with DA PAM 670-1.

#### **14-11. Manner of wear of unit award emblems**

a. Description. Unit award emblems with frames will be worn with the laurel leaves of the frame pointing upward. Only one emblem representing the same unit award will be worn. Emblems may be worn as prescribed when wearing full-size medals or service ribbons.

b. Where worn. U.S., foreign, State of Michigan, and defense force unit award emblems will be worn on the ASU/AGSU and may be worn on the class B uniform.

c. How worn. All unit award emblems with frames will be worn in the order of precedence from the wearer's right to left in rows of not more than three emblems per row and with up to 1/8-inch space between the rows. Emblems with frames will be worn centered and 1/8 inch above the right breast pocket.

d. Foreign unit awards. If a foreign unit award is worn, at least one other award must also be worn. Foreign unit awards are worn after U.S. unit awards by the date of receipt.

e. Defense force unit awards. If a defense force unit award is worn, it will follow the U.S. and foreign unit awards.

f. SGAUS unit awards. If a SGAUS unit award is worn, it will follow the U.S., foreign, and defense force unit awards.

### **Section IV - Authorized Badges and Tabs**

#### **14-12. Badges authorized for wear**

A badge is awarded to an individual for identification purposes or for attaining a special skill or proficiency. Authorization for an individual to wear a federal badge will be shown on his DD 214 or NGB 22. Defense force badges may be worn if authorized by HQDF and proper documentation is contained in the individual's 201 file.

a. The following badges are authorized for wear on the ASU/AGSU uniform:

- (1) Marksmanship badges and tabs.
- (2) Combat, special skill badges and tabs.
- (3) Identification badges.

(4) Foreign badges.

(5) SGAUS badges.

b. Consistent with DA PAM 670–1, the following badges are authorized for wear on the defense force utility uniform:

(1) Combat, special skill badges and tabs.

(2) Identification badges.

(3) SGAUS badges.

(4) Other SDF badges.

c. Jump wings and parachute badges issued by any military association or any subchapters, or by any other State Defense Force or association, are authorized to be earned by defense force personnel.

#### **14–13. Tabs authorized for wear**

a. The only tabs authorized for wear in the defense force are those awarded for completion of specialized training or affiliation with a federal service, the State of Michigan or the Michigan state defense force. Approval for service members to wear an authorized federal tab shall be reflected on DD 214, NGB 22 or official orders. Requests for authorization and wear of tabs of other State Defense Forces or recognized military organizations (or subchapters) shall be coordinated through the office of the DCS, S1 for approval.

b. In addition to federal tabs, the following are authorized tabs for defense force in order of precedence:

(1) Governor's Twenty.

(2) MEMS Academy tab for the State MEMS Director.

c. Wear. Tabs will be worn centered on the sleeve 1/2 inch below the shoulder seam of the left sleeve on the ASU and AGSU. A maximum three skill tabs identifiers can be worn at one time.

d. Shoulder sleeve insignia will be worn centered immediately below the tab.

### **Section V - Wear of Badges**

#### **14–14. Manner of wear of marksmanship badges**

Marksmanship badges will be worn IAW AR 670 –1.

#### **14–15. Manner of wear of special skills badges on ACU, ASU and AGSU Uniforms**

a. Subdued combat and special skill badges are worn on the ACU uniform above the MICHIGAN tape, in order of group precedence, from top to bottom and from the wearer's right to left. Badges may all be either sew-on or pin-on. Background material of sew on badges is not included as part of the measurement for placement of badges.

b. Personnel may wear up to five badges above the MICHIGAN tape so long as space allows for the badges on the individual's uniform. Personnel may only wear one combat or special skill badge from either group 1 or group 2. Service members may wear up to five badges from groups 3, 4, and 5. One badge from either group 1 or group 2 may be worn with badges from groups 3, 4, and 5 so long as the total number of badges on the ACU and ASU/AGSU uniform does not exceed five. The driver and mechanic badges are not authorized for wear on utility uniforms. One or more badges are worn as follows:

(1) When one badge is worn, it is centered 1/8 inch above the MICHIGAN tape.

(2) When two badges are worn, they are centered 1/8 inch above the MICHIGAN tape in a single vertical column with 1/4 inch between badges.

(3) When three badges are worn, they are centered 1/8 inch above the MICHIGAN tape either in a single vertical column with 1/4 inch between badges; or two badges are worn side-by-side, 1/8 inch above and centered on the MICHIGAN tape with 1/2 inch between badges horizontally, and the third badge is centered on the MICHIGAN tape 1/4 inch above the lower two badges (see fig 20–63 in DA PAM 670–1).

c. Service members may sew on the MICHIGAN tape, name tape, rank, and all authorized badges as an option. Hook-and-loop fasteners for MICHIGAN tape and name tape may be left on or removed when sewing on the uniform. If worn, badges must be all sewn on or all pinned on; service members are not authorized to mix sew-on badges with pin-on badges. When personnel sew on badges, the following must also be sewn on the ACU uniform coat: name tape and MICHIGAN tape, if a nametape, MICHIGAN tape or grade insignia is sewn on, then personnel must sew all three of these items on the uniform coat. This requirement does not apply to the patrol cap. If service members choose to sew on MICHIGAN tape, name tape, rank or authorized skill badges, it will be at their own expense. Service members may wear pin-on badges with sewn on name tape, MICHIGAN tape, and grade insignia. Service members are not authorized to wear pinned on badges in a field or deployed environment.

#### **14–16. Identification badges-Intent**

a. Eligible defense force personnel are authorized to accept and wear identification badges listed below. Identification badges are authorized to be worn as public evidence of deserved honor and distinction to denote service performed in specified assignments in the Organization of the DMVA and joint staff agencies; as a member of HQDF; defense force instructor, as a drill sergeant; and as a MIDF recruiter.

b. It should be noted that some of the identification badges listed above are not DA badges. Criteria and eligibility are subject to change and individuals are advised to contact the defense force badge proponent for additional information and guidance.

c. Personnel must meet the minimum criteria established by principal staff officials for permanent wear or as adapted from AR 600–8–22. Requests for exceptions to this policy must be approved by the DCS, S1.

#### **14–17. Manner of wear of identification badges**

a. Manner of wear of all identification badges is contained in AR 670–1 and DA Pam 670–1. In addition to earned federal identification badges, the following identification badges are authorized for wear on the defense force utility and service uniforms:

(1) Instructor ID badge. Worn by qualified defense force instructors who are assigned to the military training academy.

(2) Drill sergeant ID badge. Authorized for the successful completion of DMVA approved drill sergeant course and assignment as a drill sergeant to a training command.

(3) Recruiting and retention ID badge. Worn by qualified service members assigned to defense force recruiting command as recruiters.

b. Temporary badges. The following badges are authorized for temporary wear. Personnel will not wear these badges for official photographs or for promotion or selection boards. Upon termination of assignment to the command or DMVA/state agency that directs the wear of these badges, service members will discontinue wearing these badges on the uniform.

(1) Military police ID badge. Approved for all service members assigned to the office of the defense force Provost Marshal or unit level military police command carrying PMOS 98P, 99P and 990P.

c. Wearing non-subdued identification badges. Personnel may wear no more than two ID badges on one side or pocket of the ASU and no more than one ID badge on one side or pocket of the AGSU. When two ID badges are worn on the same side or pocket, the precedence of the badges is from the wearer's right (highest) to left (lowest), as listed in paragraph 22–17a of DA PAM 670–1. When more than two badges are awarded that are worn on the same side or pocket, the individual may determine which two badges are worn on the uniform. ID badges are worn as follows:

(1) Male personnel.

(a) On the ASU coat and the service uniform shirt, ID badges are worn centered on the pocket of the coat or shirt. The badge is centered between the bottom of the pocket flap and the bottom of the pocket and centered from left to right. When two badges are worn on the same side, they are spaced equally from left to right on the pocket. Personnel may wear miniature ID badges on the Class B version (service uniform) shirts but may not mix full-sized ID badges with miniature ID badges, unless badges are not available (manufactured) in miniature size (such as the combat service identification badge (CSIB)).

(b) On the AGSU, ID badges are worn centered on the pocket of the coat. Only one ID badge will be worn per side. The badge is centered between the bottom of the pocket flap and the bottom of the pocket and centered from left to right.

(2) Female personnel.

(a) On the ASU, service uniform shirt, and the maternity tunic, ID badges are worn parallel to the waistline of the coat. When two badges are worn on the same side, they are worn with 1 inch between badges. If no other awards, decorations, or insignia (other than the nameplate and rank) are worn on the ASU Class B shirts, female service members may place the ID badge parallel to the nameplate or approximately 1 inch above the nameplate, depending upon which side the badge is worn. Female service members may adjust placement of badges to conform to individual body shape differences. Personnel may wear miniature ID badges on the ASU Class B shirts but may not mix full-sized ID badges with miniature ID badges, unless badges are not available (manufactured) in miniature size (such as the CSIB).

(b) On the AGSU, ID badges are worn centered with the bottom of the badge parallel to the third buttonhole of the coat, centered on the pocket flap button. Only one ID badge will be worn per side. Female service members may

adjust placement of badges to conform to individual body shape differences.

d. Wearing subdued identification badges. Subdued badges are worn on the utility uniforms and the combat uniform, when authorized, with the badge centered on the appropriate breast pocket between the bottom of the pocket flap and the bottom of the pocket or in a similar location on uniforms without pockets. Badges will be parallel to the ground and worn centered on the pocket (not including the pocket flap). Background material of sew-on badges is not included as part of the measurement for placement of badges. Service members are authorized to move ID badges to the opposite side of the ACU coat to wear two badges normally prescribed for the same side of the ACU. Service members may move the lower precedence badge to the left side of the ACU coat. Service members remain limited to a total of two ID badges on the ACUs, one per side. This authorization affects the following ID badges: drill sergeant; recruiting and retention (MIDF); and the instructor ID badges. Service members are authorized to wear only one recruiting badge on their uniform at a time.

#### **14–18. Manner of wear of foreign badges**

a. Where worn. Service members may wear one foreign badge on the AGSU coat, ASU coat, ASU shirt, and ASU–M tunic (female service members only). Foreign badges are not authorized for wear on utility uniforms. Personnel may not wear a foreign badge unless at least one U.S., State of Michigan, SDF or SGAUS badge, medal or service ribbon is worn at the same time. Personnel may not wear foreign badges that are awarded only as cloth badges and personnel may not wear foreign badges that cannot be worn properly because of size or configuration.

b. How worn.

(1) Male service members wear the foreign badge centered and 1/8 inch above the right pocket flap or 1/2 inch above any unit awards that are worn.

(2) Female service members wear the badge centered and 1/2 inch above the nameplate or 1/2 inch above any unit awards that are worn.

(3) On the AGSU, service members wear the foreign badge centered and 1/8 inch above the right pocket flap or 1/2 inch above any unit awards that are worn).

(4) In those instances where the coat lapel obscures the badge, personnel may wear the badges aligned with the right edge of unit awards or the nameplate.

#### **14–19. Manner and wear of shoulder cords**

a. Shoulder cords awarded by the United States, a State Defense Force or awarded by a foreign government in the course of service to the United States or State, will be worn IAW the provisions of AR 670–1.

b. Proper wear reference is DA Pam 670–1.

### **Chapter 15**

## **Wear of the Uniform by Retired and Former Service Members**

#### **15–1. General guidelines**

This section addresses the wear of any defense force uniform by retired and former members of the defense force. The remaining guidance is found in Reference: AR 67–1, Sections 23-3 and 23-4.

#### **15–2. Wear by retired personnel**

a. Personnel who will be advanced to a higher grade upon retirement have the option of wearing the insignia of that grade thereafter.

b. Retired personnel in active service will wear their uniform and insignia in the same manner as prescribed for personnel in the defense force of corresponding grade and branch.

c. Retired personnel not in active service may wear either the uniform reflecting their grade and branch on the date of their retirement, or the uniform prescribed for personnel in the defense force of corresponding grade and branch, when appropriate, but may not mix the two uniforms. Personnel will wear the grade as shown on the retired grade of rank line on their retirement order.

d. Retired personnel not in active service are not authorized to wear the defense force uniform when they are instructors or responsible for military discipline at an educational institution, unless the educational institution is conducting courses of instruction approved by DMVA and/or the defense force.

e. In addition to the occasions for wear listed above, retired personnel are authorized to wear the uniform only on the following occasions:

(1) While attending military funerals, memorial services, weddings, inaugurations, and other occasions of



ceremony.

(2) Attending parades on national or state holidays, or other patriotic parades or ceremonies in which any Regular or Reserve U.S. military unit or State Defense Force is taking part. Uniforms for these occasions are restricted to service and dress uniforms; the combat uniform and physical fitness uniforms will not be worn. Wearing the defense force uniform at any other time, or for any other purpose than stated above, is prohibited.

f. Retirees are authorized to wear the physical fitness uniform under the following provisions:

(1) With civilian attire off the installation.

(2) When wearing the physical fitness uniform as a complete uniform, retirees will—

(a) Wear only authorized accessories corresponding to those worn by personnel of the defense force.

(b) Wear the uniform in accordance with the guidance provided to defense force service members (see DA Pam 670–1).

g. Retirees are authorized to wear the Retired Service Identification Badge (see DA Pam 670–1).

h. Retirees are authorized to wear the Retired SSI (see DA Pam 670–1).

### **15–3. Wear by former members.**

a. Unless qualified under another provision of this regulation, or under the provisions of 10 USC 772, former members of the defense force may only wear the uniform if they served honorably during a declared or undeclared war, declared or undeclared disaster/emergency or if their most recent service was terminated under honorable conditions. Personnel who qualify under these conditions will wear the defense force uniform in the highest grade they held during such service, in accordance with 150 PA 1967.

b. When authorized, the uniform may be worn only for the following ceremonial occasions and when traveling to and from the event and must follow guidance included in paragraph 3–7c.

(1) When attending military funerals, memorial services, weddings, inaugurations, and other occasions of ceremony.

(2) When attending parades on national or state holidays, or other patriotic parades or ceremonies in which any Regular or Reserve U.S. military unit or State Defense Force is taking part. Uniforms for these occasions are restricted to service and dress uniforms; the combat uniform and physical fitness uniforms will not be worn. Wearing the Army uniform at any other time, or for any other purpose than stated above, is prohibited.

## **Chapter 16**

### **Alternate Uniform Ensemble**

#### **16–1. Classification**

a. The alternate uniform (Class D) is required if service members fail to meet the requirements of Defense Force SOP 600-9, Body Composition Program.

b. The Class D uniform is mandatory for any service member with a body mass index (BMI) of 34 or above.

c. Defense force commanders may prescribe the Class D uniform for training or mission support when wear the ACU uniform is deemed in appropriate.

d. Uniform items commonly associated with the wear of bot Class A, B and C uniforms shall not be mixed and worn with the Class D uniform with the exception of these items:

(1) Belt, rigger.

(2) Socks, tan, green, or black; cushion sole.

(3) Boots, combat, leather.

#### **16–2. Composition**

The alternate uniform consists of the following:

a. Shirt: polo type, solid navy blue with MIDF logo. Shirt to be worn tucked into trousers.

b. Trousers: tan; cargo, tactical type. Trousers legs to be bloused at boots.

c. Undershirt.

d. Undergarments.

e. Belt, rigger.

f. Socks: tan, green, or black; cushion sole.

g. Boots: combat, leather.

h. Headgear: solid navy blue; MIDF logo preferred (if worn).

i. Rank: subdued colored, pin-on worn on both collars.



**Figure 16-1. Class D (Alternate) uniform**

## APPENDIX A

### Branch Colors

#### A-1

Current U.S. Army branch colors as described in AR 670-1, Wear and Appearance of Uniforms and Insignia, will be used when branch colors are specified. Scarlet has been adopted as the branch color for the SDF by most State Defense Forces and State Guards. This is reflected in the red beret flash and red nameplate.

The following branch colors are authorized by personnel for wear when assigned to the appropriate section:

- a. Adjutant General's Corps. Dark blue and scarlet (cable numbers 65012 and 65006).
- b. Army Medical Specialist Corps. Maroon and white (cable numbers 65017 and 65005).
- c. Army Nurse Corps. Maroon and white (cable numbers 65017 and 65005).
- d. Branch immaterial. Teal blue and white (cable numbers 65024 and 65005).
- e. Chaplain Corps. Black (cable number 65018).
- f. Chemical Corps. Cobalt blue and golden yellow (cable numbers 65011 and 65001).
- g. Dental Corps. Maroon and white (cable numbers 65017 and 65005).
- h. Finance Corps. Silver gray and golden yellow (cable numbers 65008 and 65001).
- i. Judge Advocate General's Corps. Dark blue and white (cable numbers 65012 and 65005).
- j. Medical Corps. Maroon and white (cable numbers 65017 and 65005).
- k. Medical Service Corps. Maroon and white (cable numbers 65017 and 65005).
- l. Military Intelligence. Oriental blue and silver gray (cable numbers 65027 and 65008).
- m. Military Police Corps. Green and yellow (cable numbers 65007 and 65002).
- n. Quartermaster Corps. Buff (cable number 65015).
- o. Signal Corps. Orange and white (cable numbers 65004 and 65005).
- p. The Inspector General. Dark blue and light blue (cable numbers 65012 and 65014).
- q. Support Operations Command. Dark blue and white (cable number 65012 and 65005).
- r. Support Operations Command/Det. Tan 499
- s. Transportation Corps. Brick red and golden yellow (cable numbers 650 and 65001).

## APPENDIX B

### CLOTHING BAG LIST – MANDATORY POSSESSION

#### B-1. Required clothing bag items.

All defense force service members are required to possess the clothing bag items in the quantities as outlined in Table B-1. Personnel may purchase and wear commercially available optional items authorized by DA PAM 670-1 and this SOP.

**Table B-1**

<b>List of major components:</b>	<b>Minimum number</b>
Tag, Identification, w/chains, set	1
Nametape, MICHIGAN	2
Nametape, individual	2
Insignia, shoulder sleeve, defense force, subdued	1
Jacket, cold weather	1
Liner, cold weather jacket or Fleece Jacket	1
Jacket, ACU	1
Trousers, ACU	1
Cap, Patrol ACU	1
Undershirt	2
Socks, tan, green or black, w/cushion sole	2
Boots, Combat	1
Belt, nylon, riggers (w/ACU Uniform)	1
Gloves, leather, shell, pair	1
Insert, wool, gloves, pair	1

**APPENDIX C**

**Authorized optional purchase item list.**

**C-1. Optional purchase item list**

The following list represents optional purchase items authorized (and recommended) for all defense force service members as described in this SOP. This is not an all-inclusive and subject to change. Service members are advised to inquire through their chain of command for clarification.

**Table C-1**

<b>Optional purchase item list:</b>	<b>#</b>
Scarf, wool	1
Sweater, wool	1
Nameplate, red	1
Insignia, state (M.I.), bright	1
Insignia, branch, bright	1
Coat, ASU/AGSU	1*
Trousers, ASU/AGSU	1*
Shirt, ASU/AGSU men's, long sleeve	1*
Shirt, ASU/AGSU men's, short sleeve	1*
Shoes, oxford,-pair	1*
Socks, dress, pair	1*
Belt, web, cotton, w/brass tip & brass buckle	1*
Cap, garrison, men's	1*
Beret, black w/ red SDF Flash	1
Sweater, wool, pullover	1
Necktie	1*
Coat, all weather, men's	1*
Coat, ASU/AGSU, women's	1**
Skirt, ASU/AGSU, women's	1**
Slacks, ASU/AGSU, Women's	1**
Shirt, ASU/AGSU women's, short sleeve	1**
Shirt, ASU/AGSU women's, long sleeve	1**
Tab, neck	1**
Pumps, pair	1**
Handbag	1**
Cap, garrison, women's	1**
Coat, all weather, women's	1**
* men only    ** women only	